

The Emotion of Motion

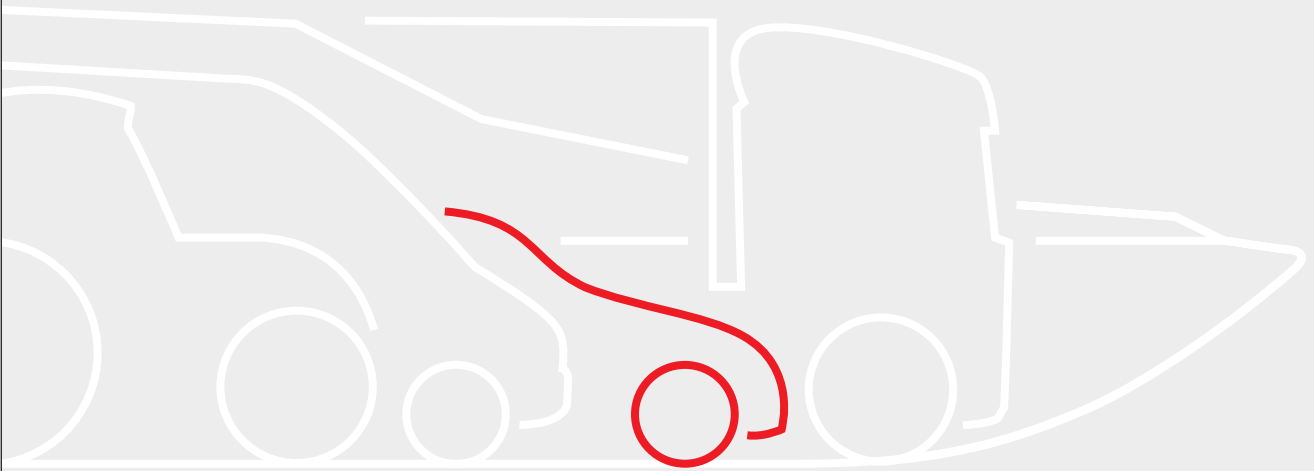

Installation Guide Power enhancement



tuning technologies
STEINBAUER





tuning technologies
STEINBAUER

STEINBAUER Tuning Technologies is an innovative manufacturer of electronic components and additional modules for the worldwide vehicle market.

Our aim is to supply you with results, not only products.

Thank you for choosing to buy from STEINBAUER.

The Emotion of Motion.

www.steinbauer.cc



Important information

To be able to take the benefits of all technical advantages of your newly purchased STEINBAUER Additional electronic, please consider the following advices.

Do not use the STEINBAUER Additional electronic before you have read and understood the "Important information".

The installation confirms that the buyer has read, understood and accepted the "Important information".



Please read all instructions carefully before installation.

- Do not install the STEINBAUER Additional electronic on running ignition. Wait after stopping the ignition, because the ECU needs a few minutes to stop completely. For some vehicles you have to pull out the ignition key and close the driver's door.
- To avoid any damages and therefore caused malfunctions, fix the STEINBAUER wiring loom with cable fasteners. Take care that the STEINBAUER wiring loom does not touch or rub on metal parts. In case of malfunctions caused by not fixed cables or by inappropriate installation the STEINBAUER manufacturer's guarantee and liability for consequential damage of STEINBAUER Tuning Technologies Austria GmbH expires. We grant a three years' guarantee starting at dispatch, but only in case of appropriate installation and usage.
- If you have any questions when installing, please do not hesitate to contact STEINBAUER Tuning Technologies Austria or your nearest sales partner.
- As manufacturer of the STEINBAUER Additional electronic we are obliged to inform you, that any changes made to a vehicle licensed for public transport, must be notified to the appropriate inspection authority and inserted to the car documents. The legal restrictions are different in each country, therefore please check with appropriate authority.
- Please read our general terms.

DO NOT USE THE STEINBAUER ADDITIONAL ELECTRONIC BEFORE YOU HAVE READ AND UNDERSTOOD THE "IMPORTANT INFORMATION".

SEE "IMPORTANT INFORMATION".

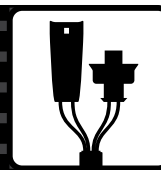

Installation

How it works

The STEINBAUER Power enhancement modifies the injection system by fine tuning the duration of the injectors. This is achieved by blue printing the original characteristics and intercepting the electronic signals from the ECU to the injection system. The fuel injection and engine speed are recorded and recalculated to optimize performance. To guarantee a clear combustion boost pressure is raised up slightly.

Installation

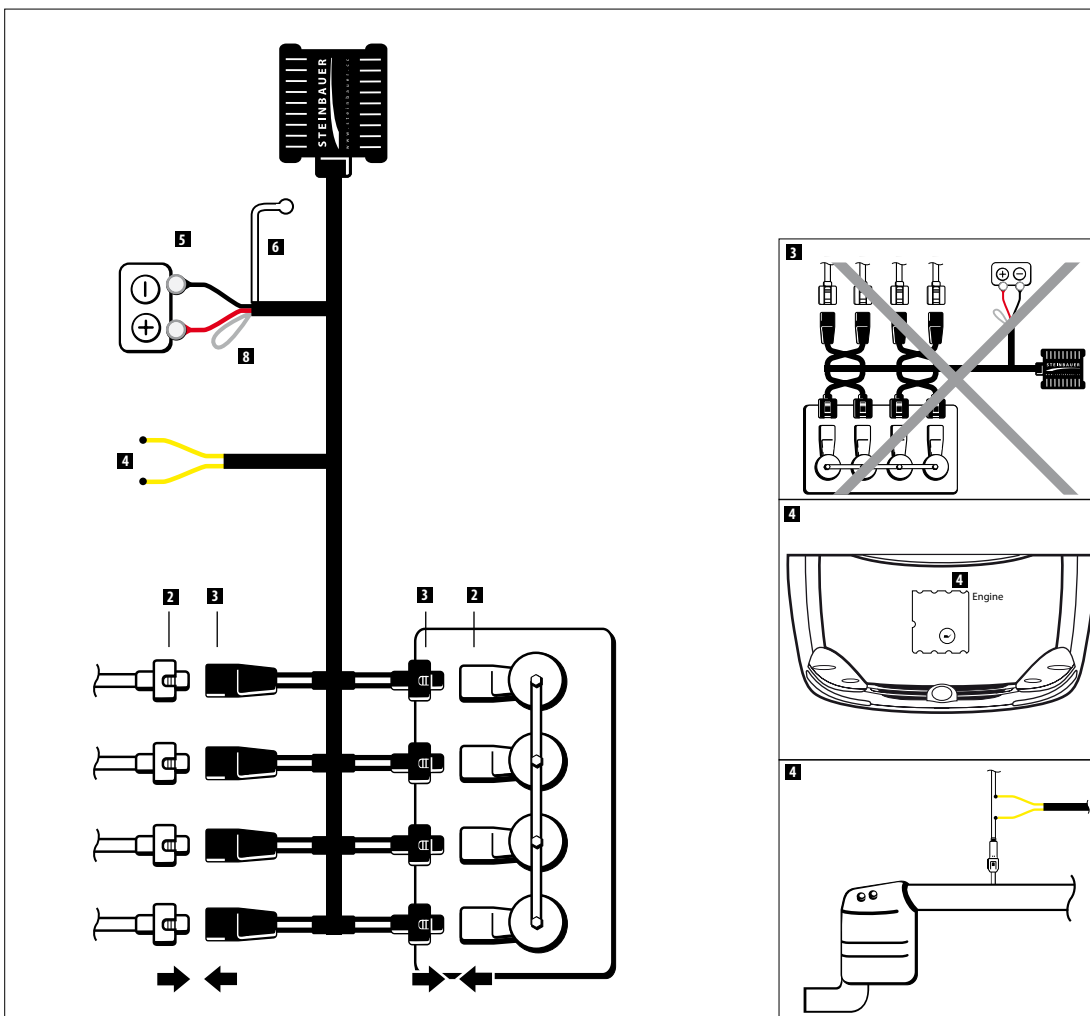

- 1 Remove the engine covers.
- 2 Disconnect the plug connections at the injectors.
- 3 Plug in the connectors of the STEINBAUER wiring loom.
NOTE! Maintaining the correct order is absolutely necessary. Do not plug in cross-over.
- 4 Cut one wire from the two wires between exhaust gas temperature sensor and ECU and connect one yellow wire of the STEINBAUER Power enhancement to each end.
- 5 Connect red wire to +12V and black wire to chassis ground.
- 6 Reference signal wire (see „Connection for the reference signal“).
- 7 Refit the engine cover.
- 8 Switch wire (see „Accessories“)

NOTE: Usage of our products causes the expiry of the manufacturer's warranty.



INT 04/06

5

Connection for reference signal

The connection of a reference signal is absolutely necessary to optimise performance.

Connection

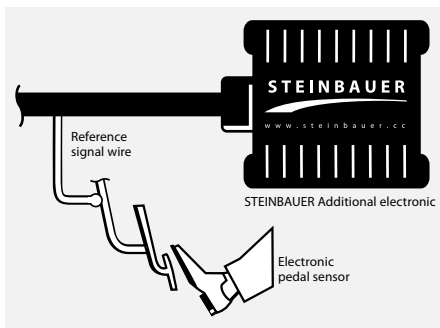

Solder the reference signal wire on the wire of the electronic pedal sensor.
The colour of the electronic pedal sensor wire for the connection of the reference signal may vary, therefore you have to ascertain the correct wire with the LEDs inside the STEINBAUER Additional electronic.

Control of function

Explanation of symbols

LED: = on = flashes = off

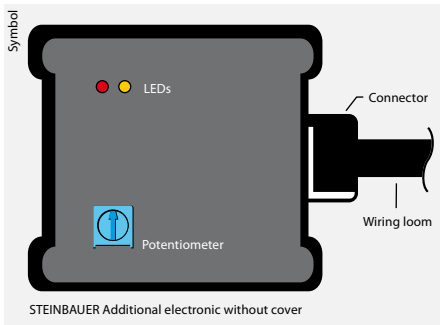

STEINBAUER Additional electronic without cover

1 Ignition on (do not start engine)

- rt** - power supply correct
- rt** - power supply not correct or electronic defect
- ge** - LED flashes slowly on idle setting of electronic pedal sensor (0,5 – 1 V)
- flashing frequency raises on full loading setting (3 V-4,9 V)
- ge** - Reference signal connected incorrect (> 5 V)
- ge** - Reference signal connected incorrect (< 0,5 V)

2 Start engine

- rt** - the flashing frequency raises according to engine speed
- rt** - check wiring loom; if installed correct, electronic defect
- rt** - electronic defect
- ge** - Switch closed position (off) = original power
- ge** - Switch open position (on) = power enhancement



Open the STEINBAUER Additional electronic with the appropriate tool.



The position of the potentiometer may vary.



Colour abbreviations
ge = yellow | rt = red

Fine adjustment of the STEINBAUER Additional electronic

Due to original tolerances of manufacturing the preset characteristic map of the STEINBAUER Additional electronic may offer too much or too less power enhancement.

An inflated characteristic map causes more soot creation, engine misfires, bumpy idle running (variations of revolution speed), "bucking", stop or emergency mode of engine (severe less power) or flashing of defect control lights.

You can remedy these defects by fine adjustment of the STEINBAUER Additional electronic with the Potentiometer. The adjustment of the Potentiometer does not adversely effect the power enhancement.



Adjustment of the characteristic map

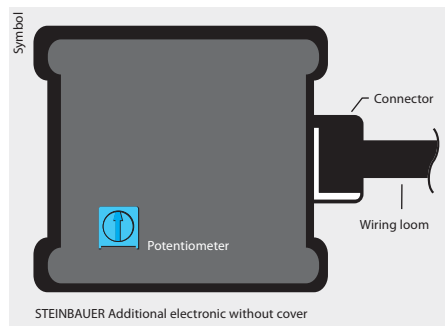

100 %



Normal characteristic map

The fine adjustment can be done with the potentiometer.

The figure shows the standard adjustment of the potentiometer made at production, normal characteristic map = 100%.

! Normal characteristic map = Original power enhancement +20% !



Open the STEINBAUER Additional electronic with the appropriate tool.



The position of the potentiometer may vary.

130 %



Enhancement of the characteristic map

- Turn the potentiometer to the right in small steps (clockwise).
- Have a test-drive.
- Repeat this procedure until all problems are solved.

50 %



Reduction of the characteristic map

- Turn the potentiometer to the left in small steps (anti-clockwise).
- Have a test-drive.
- Repeat this procedure until all problems are solved.



Accessories

To turn on/off the STEINBAUER Additional electronic.

Switch

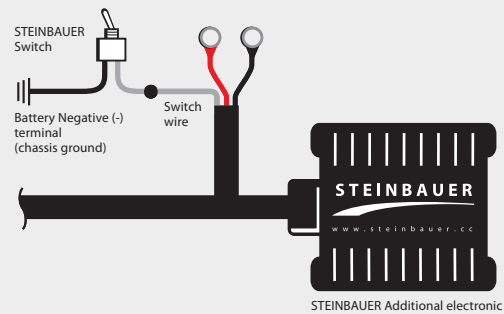

Installation

Connect the grey wire of the switch to the Switch wire (grey wire of the STEINBAUER Additional electronic). Connect the black wire of the switch to the battery Negative (-) terminal (chassis ground).



Power enhancement:
Switch in open position

Original power:
Switch in closed position



You can order the switch separately. Part no. 200086.

Remote Control

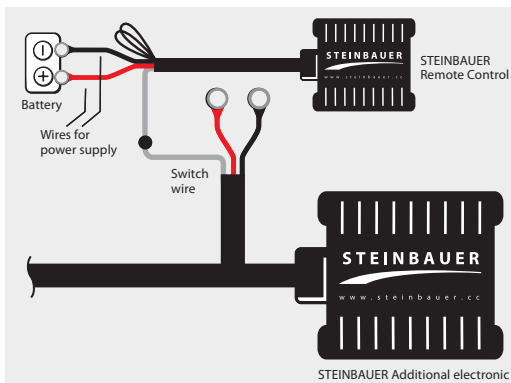

Installation

Connect the red wire to the battery Positive (+) terminal, black wire to the battery Negative (-) terminal. Connect the grey wire of the remote control to the Switch wire (grey wire of the STEINBAUER Additional electronic).

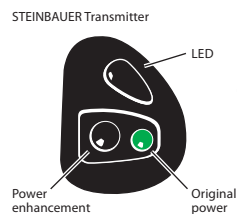

Power enhancement:
Press the black button

Original power:
Press the green button



You can order the remote control separately. Part no. 200089.



Terms and Conditions

All our deliveries are made on the basis of our following sales and delivery conditions. Modifications or additional agreements need to be confirmed in writing to be valid. This General Terms & Conditions are available in English and German. In case of any divergence between the two versions the German version shall prevail. Other purchasing conditions of the buyer is hereby rejected; you do not commit ourselves, not even if we don't disagree at the time of the conclusion of contract. Even the sending of an order confirmation by the purchaser shall not be considered as recognition of the conditions of the buyer, nor is the non-confirmation as tacit acceptance of the conditions of the buyer. At least with the receipt of the goods subject to our conditions than accepted. These conditions also apply, without further specific basis for all our transactions with the customer.

1. Order Confirmation

Our offers are in all parts of engagement. The order is accepted on that day we send a written confirmation. All changes to our certification requirement need a written confirmation by us. Phone agreements and all agreements of any kind require our written confirmation. Oral orders are considered binding. We reserve design and format changes. For illustrations, drawings, sketches and other documents we retain ownership rights and copyrights.

2. Delivery

The supply and the charging results from price and terms from the day of shipment or pickup. The goods are packed as standard. The goods are only insured against transport damages, total loss or break if the customer requires in written form. The insurance costs are invoiced to the customer. The customer is committed to check the goods immediately after receipt or latest within five working days after receipt. If the customer is an entrepreneur in the legal sense of the appropriate assignments of the UGB (Austrian Business Enterprise Code), the object of purchase is to check immediately after receipt according to § 377 ff. UGB (Business Enterprise Code) assessed accuracy and determinable defects are to note on the Delivery Note or waybill at other exclusion of any claims. The customer loses the right to invoke a delivery contrary to the contract, if he omits this immediate check or if he does not complain the contract infringement immediately after the point of time when he should notice them at a correct check. The complaint has to be done in written form stating an exact description of the infringement of contract. Visible transport damages have to be complained at receipt of the goods and the type and scope of damage has to be notified to the supplier in written promptly. The delivery respites are only approximate and run from the date of order confirmation. For their compliance is no liability. Even with fixed dates in the case of default you have to give us a reasonable period of time. In the event of default deadline the purchaser may resign. Claims for damages or penalties are excluded. Force majeure of any kind in our own business or that of the suppliers without further reasons entitle us to dissolve the delivery obligations or delaying the delivery time. The customer has no claims for rescission or cancellation of the contract. The return of sold goods is not permitted. In the case of withdrawn good, the net price plus tax is refunded - but not exceeding the amount paid. Above is not applied in the case of the Reservation of Property Rights. If the delivery is agreed on demand, we are entitled to deliver and to charge the finished products after 2 months after we show our readiness to deliver, even if the customer doesn't make the demands.

3. Shipping

The dispatch is always at the expense and risk of the customer. The risk with delivery ex works or from storage pass to the customer, even if the supplier has taken over the extradition. If shipment is delayed through the fault of the buyer, the risk passes to the customer on the day of readiness of shipment.

4. Prices

Our prices include, unless otherwise stated, no value added tax. They apply from the factory without packing, without transport insurance, freight and installation. Taxes, contract fees, execution fees, import fees, customs and customs charges, official commission fees and suchlike costs bears the customer. In the event of significant price increases of raw materials or statutory wage increases, we are entitled to change prices or to resign from the contract.

5. Payment

Our invoices are due within 7 days after the invoice date net cash for payment. We are entitled to charge in excess of that payment deadlines without warning banker's interest, but at least default interest of 8% above the current discount rate of the Austrian National Bank. The assertion further rights are reserved. The buyer is not entitled to repress or to add payments, not even because of complaints or counter-claims. We reserve the right of the collection of bills and cheques from case to case to decide. The credit is only under normal reservation. For foreign exchange, we discount the bank and collection expenses. We can't guarantee for timely collection or timely protest. Staff member of the supplier are only allowed to accept payments with an explicit authorization in written. Received payments are accumulated to the interests first, and then deducted from the suppliers oldest receivables against the customer. The customer is not allowed to deduct any counterclaims from the receivables of the supplier. The customer is not authorized to retain any money due to warranty requests or other requests which have not been accepted by the supplier. In the event that an exchange or a cheque is not cashed that there will be a payment default, or other circumstances of the purchaser occur, in our view, granting a target no longer justified, the entire claim - even if this exchange or cheques to - is due immediately.

6. Reservation of Property Rights

The goods remain our property until payment of all existing claims and arising claims in the future, including all incidental claims from our business relationship with the buyer. This includes claims from exchange and cheques. The buyer may realise the conditional goods against payment or dispose of property subject. The buyer is not entitled to pledge or assign as security. The buyer already assigns to us the claims of deliveries, in which conditional goods are included, the amount with all ancillary rights, which conforms to the invoice price of the conditional goods.

In the event that the demands of the buyer from the resale in a current account, hereby the buyer already assigns his claims from the current account to his customers to us, in the amount of price that we charged him for the resold reserved goods. Until cancelled the buyer is entitled to revoke his assigned book account to us. If we due our overall requirement of paragraph 5 immediately, the buyer is obliged to consider our request, to inform the debtors of the assignment, and to provide us with information and documents. The assertion of ownership and the distraint of the goods delivered by the supplier are not considered resignation from the contract, unless the law for instalment sales applies.

If the Reservation of Property Rights expires due to any circumstances, supplier and customer now agree that the property of the goods with processing, commingling or mixture are passed to the supplier who accepts the transfer. In this case the customer has to deposit the goods free of charge. At the processing of objects which are not yet in property of a third party the supplier acquires joint ownership share to the new goods. The scope of the joint ownership results from the proportion of the invoice value of the goods delivered by the supplier and the invoice value of the rest of the goods. If a bankruptcy proceeding is opened against the customer's property, it is not allowed to sell goods from the bankrupt's asset which are under Reservation of Property Right from the point of time of the opening of bankruptcy.

7. Duty of care

The buyer has to ensure that any changes and modifications to the public road participating vehicles to register to the motor vehicle registration certificate in accordance with the statutory provisions. All claims by the buyer or third party against the seller from accidents of any kind are expressly excluded. Vehicles which were equipped with parts, which are purposed for sports or for export to countries outside Austria, are not allowed on public roads. Motorsport parts are high-performance products and sometimes not for public roads allowed!

8. Defects and liability for defects in the delivery

A notice of defects indicated according to point 2 of these terms and conditions does not affect the payment conditions. We definitely do not give any guarantee or warranty for defects of any types of our products (neither for products on loan basis). Demands and claims against Steinbauer Tuning Technologies for compensation of damages which are not contained to the delivery item, but resulted as indirect damage (consequential damage) are explicitly excluded. Further the liability from title compensation as well as warranty in case of own installation or installation by a third party as well as the use of the products for sports or racing purposes is not assumed. Recourse receivables according to § 12 of Product Liability Act are excluded, unless the recourse authorized provides the evidence that failures have been caused by Steinbauer Tuning Technologies Austria GmbH or have been caused at least wantonly negligent. Our pretended guarantee is limited to business processes on which our warranty and guarantee conditions have been accepted and thus became content of the agreement (please see our homepage).

9. Product identification

A change in our products and any special identification mark, as a mark of origin or a third party buyer, or might appear that this is a special character, are inadmissible.

10. Place of performance and jurisdiction

The place of performance for all mutual rights and obligations is Enns. Only and exclusively Austrian right - formal as well as material right - is valid under explicit exclusion of the agreement of the United Nations about contracts about the International Sale of Goods (UN-Sales Law) or other reference provisions. For all in connection with the contractual relationship resulting disputes, also for resignation similar rights, regardless of the amount of the matter in dispute, the Jurisdiction is Linz/Austria.

The buyer must not assign his contractual rights without our explicit consent to third parties. The contract will not be ineffective as a whole by the ineffectiveness of individual provisions. The ineffectiveness of a point of these conditions doesn't affect the rest of the content and their effectiveness.

STEINBAUER Tuning Technologies Austria GmbH
Neu Gablonz 5 - A-4470 Enns
T: +43 / (0)7223 / 811 75 - 0
F: +43 / (0)7223 / 811 75 - 40
E: info.at@steinbauer.cc
www.steinbauer.cc

The Emotion of Motion.



w w w . s t e i n b a u e r . c c



HEAD QUARTER:

STEINBAUER
Tuning Technologies Austria GmbH
Neu Gablonz 5
4470 Enns
T: +43 / (0)7223 / 811 75-0
F: +43 / (0)7223 / 811 75-40
E: info.at@steinbauer.cc

tuning technologies
STEINBAUER