



NISSAN Patrol ZD30DDTi

Direction-Plus™ COMBO KIT

Pre-Line Plus Pre-filter & ProVent Kit Installation Guide

Pre-Line Plus pre-filter Kit Installation Guide

This document is to be used as a guide for the installation of the **Direction-Plus™ Pre-Line Plus Kit** to a **Nissan Patrol ZD30DDTi (2006-2018)**. It is recommended that the installation of the product be carried out by a competent qualified mechanic.

Important before starting

- Ensure the engine bay is clean and free from contaminates
- The fuel manager filter head has direction arrows indicating the direction of flow
- You have the correct tools to complete the fitment
- Read the instructions in full and familiarize yourself with the installation, before commencing any work

Kit contents

- 2x M16x1.5 ADAPTER - 10MM
- 2x M16 FLAT WASHER
- 1x M10 - 2 BOLTS 2 NUTS 4 WASHERS
- 2x M6 SPRING WASHER
- 2x M8 SPRING WASHER
- 1x M6x12 BOLT
- 1x M8x16 BOLT
- 1x PL150 MOUNTING BRACKET
- 2x 10MM FUEL LINE
- 1x WATER ALARM KIT
- 1x PL150DP
- 1x ENGINE BAY LABEL
- 2x HOSE CLAMP - 10MM
- 2x PUSH ON STRAIGHT FITTING - 10MM
- 2x WASHER - 6MM
- 1x WINDSCREEN LABEL
- 1x WATER ALARM KIT

Pre-filter mounting location

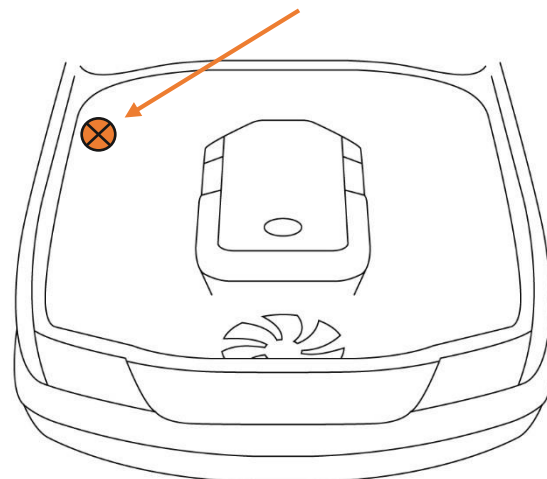

*Kit contents are subject to change based on component availability and/or refinement

Installation Guide

1. Begin by bolting the new bracket to the driver's side, just behind the fuse box. There are two factory unused threaded holes for the bracket to mount to. The top one uses the M6x12 bolt and spring washer, the bottom one uses the M8x16 Socket cap and spring washer.



Rear drivers side of engine bay, looking from front of engine bay back

2. Bolt the fuel filter assembly into place, using the M10x30mm bolts and nyloc nuts, making sure to use a flat washer under each bolt head and nut. Adjust the position of the fuel filter assembly to make sure there is clearance from the A/C line and the wiring harness. Once you are happy with the location, tighten the bolts and nuts to retain in place.
3. Fit the two M16x1.5 adapters and M16 flat washers to the PL150 head so that they face towards the rear of the car. **You may need to remove and reposition the existing blanking plugs**
4. Disconnect the fuel supply line to the factory fuel filter and remove the hose completely. Run the new hose from the rigid fuel supply line to the inlet port on the PreLine 150 and cut to length. Use a 12-20mm clamp to secure in place at the factor fuel line.
5. Lubricate the barbed end of the push-lock fittings and the inside portion of the hose to be fitted with a pushlock fitting with diesel fuel or WD40.
6. Insert the barbed end of one (1) of the push-lock fittings into the pre-lubricated end of the hose. Ensuring that the hose is firmly stopped against the inside of the bell cover.
7. Paying attention to the directional arrows, attach the assembled fuel supply hose to the inlet of the PL150



8. Connect the remaining fuel hose to the inlet side of the factory fuel filter and secure with a hose clamp.
9. Route the fuel hose to the outlet side of the PL150 and cut to length.
10. Lubricate the barbed end of the push-lock fittings and the inside portion of the hose to be fitted with a push-lock fitting with diesel fuel or WD40
11. Insert the barbed end of one (1) of the push-lock fittings into the pre-lubricated end of the hose. Ensuring that the hose is firmly stopped against the inside of the bell cover.
12. Paying attention to the directional arrows, attach the assembled fuel supply hose to the outlet of the PL150
13. Using the manual priming pump on the top of the factory fuel filter, pump until firm.
14. Once complete start the vehicle, carefully and toughly checking for leaks
15. Run the vehicle for at least 20 minutes to ensure there are no air pockets in the fuel system. You may need to repeat number 13 if the engine stalls.

END OF GUIDE

REFER TO WATER ALARM INSTRUCTION FOR FITMENT OF THE WATER ALARM

Nissan Patrol ZD30DDTi Direction-Plus™ ProVent® Ultimate Catch Can Installation Guide

This document is to be used as a guide for the installation of the **Direction Plus™ ProVent Ultimate Catch Can Kit to a Nissan Patrol ZD30DDTi (2006-2018)**. It is recommended that the installation of the product be carried out by a competent qualified mechanic.

Important Before Starting

- Ensure you have the correct tools to complete the fitment
- Read the instructions in full and familiarize yourself with the installation, before commencing any work

Included in the kit

1 x Mann + Hummel ProVent 200
1 x Mounting Bracket
1 x 500mm of 16mm Hose
1 x 75mm of 16mm Hose
1 x 300mm of 12mm Hose
2 x 16mm 90° Joiner
1 x 16mm to 12mm Joiner
6 x 16mm Spring Clamps
2 x 25mm Spring Clamps
2 x 12mm Spring Clamps
2 x 16mm to 25mm Hose Coupler
8 x Cable Ties
3 x M6x12 Bolt
3 x M6 Nyloc Nut
6 x M6 Flat Washers
2 x M8x25 Bolts
4 x M8 Flat Washers
2 x M8 Spring Washers
2 x M8 Stainless Steel Nuts
1 x 1000mm of 12mm Hose
1x Drain Tap Assembly
2 x 12-20mm Hose Clamps

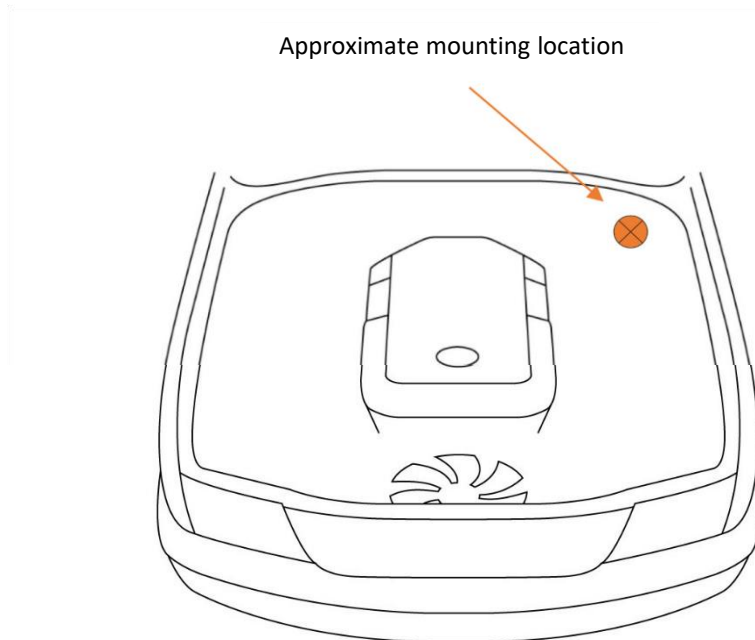

*Kit contents are subject to change based on component availability and/or refinement

Installation Guide

1. Begin by removing the engine cover (not on all models) to give access to the crankcase bypass hose in the front passenger corner.

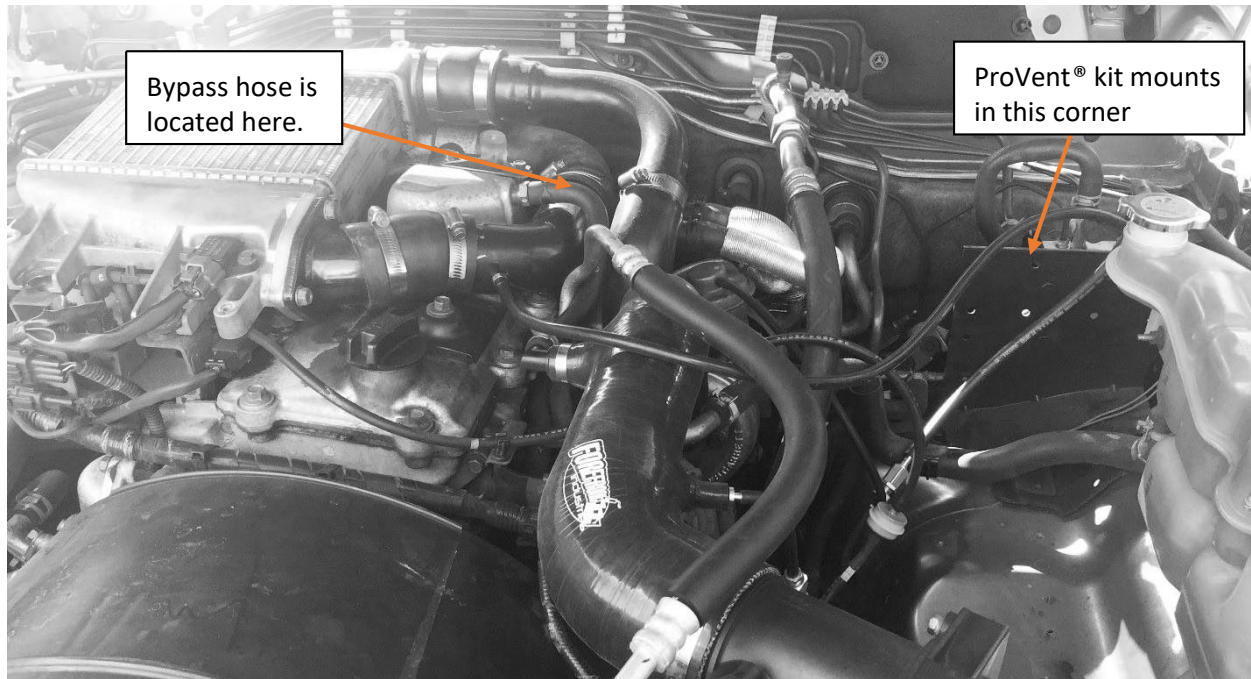

Nissan Patrol GU ZD30 Engine Bay – Overall View

2. Begin by locating the factory bypass hose which runs from the hump in the valve cover on the passenger side to the intake pipe in front of it. The hose is only about 200mm in length and shaped like an "L". Once located, this hose needs to be removed.
3. Using the three (3) supplied M6 bolts and nuts, secure the mounting bracket in place behind the black plate in the engine bay. It uses three unused factory threaded holes to locate and mount from. Please note the "kink" in the bracket should angle towards the rear of the vehicle.

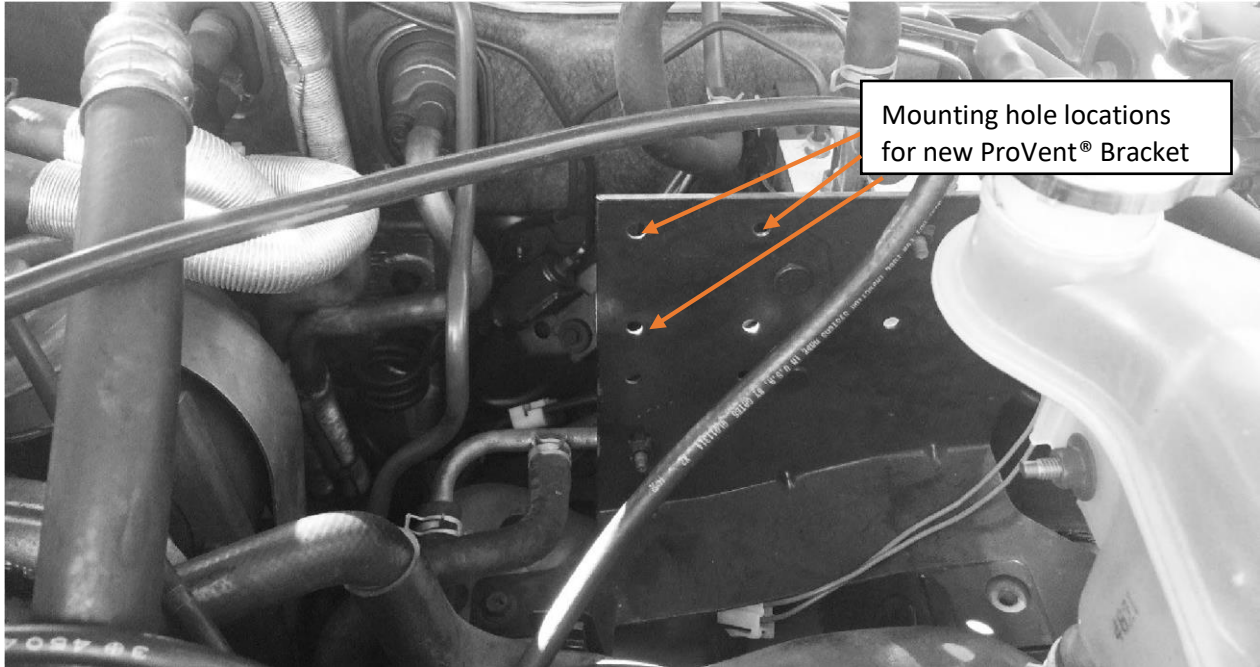

Front view: image shows new ProVent bracket location

4. Connect the 12mm (1/2") Hose to the underside of the catch can body, using a 12-20mm worm drive clamp to secure it in place.

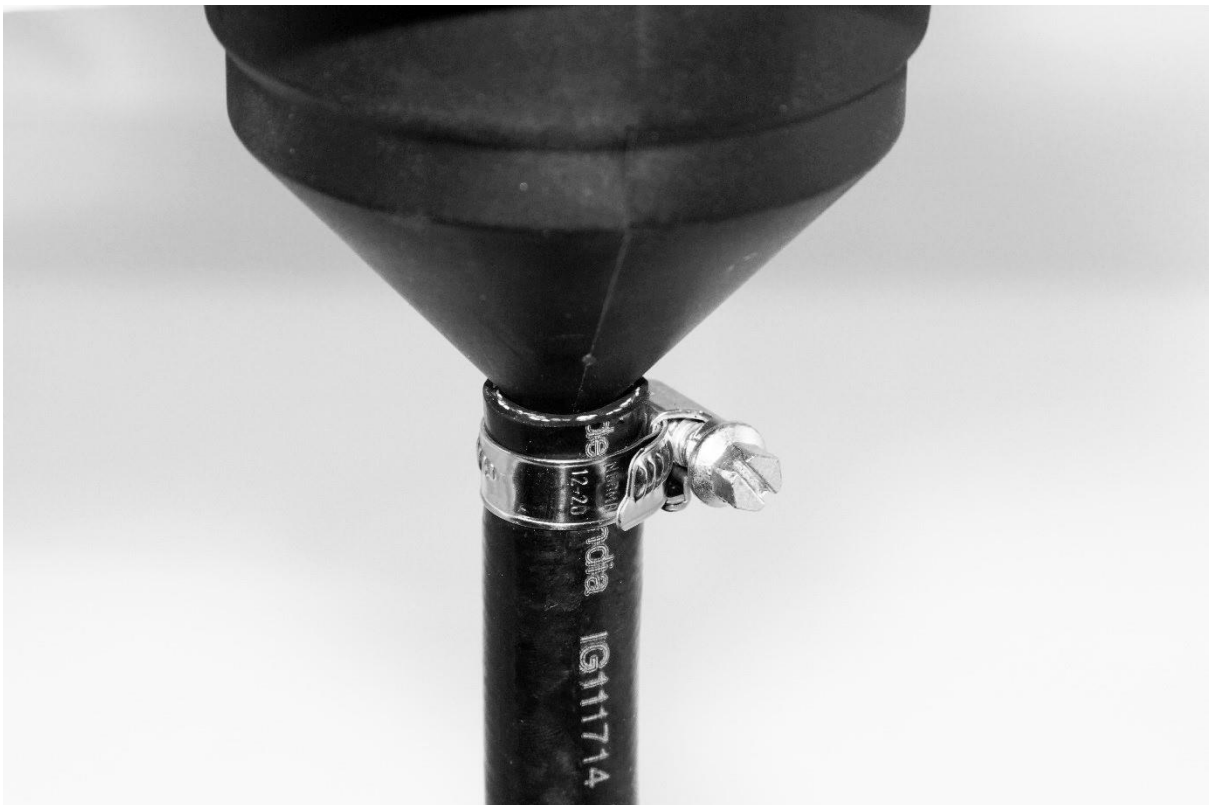

Provent® 200 with 12mm hose connected and secured with 12-20mm worm drive clamp

5. With a flat washer on each of the M8x25mm bolts, mount the ProVent® 200 to the mounting bracket. Use a flat washer, spring washer and nut to secure the bolts on the other side.

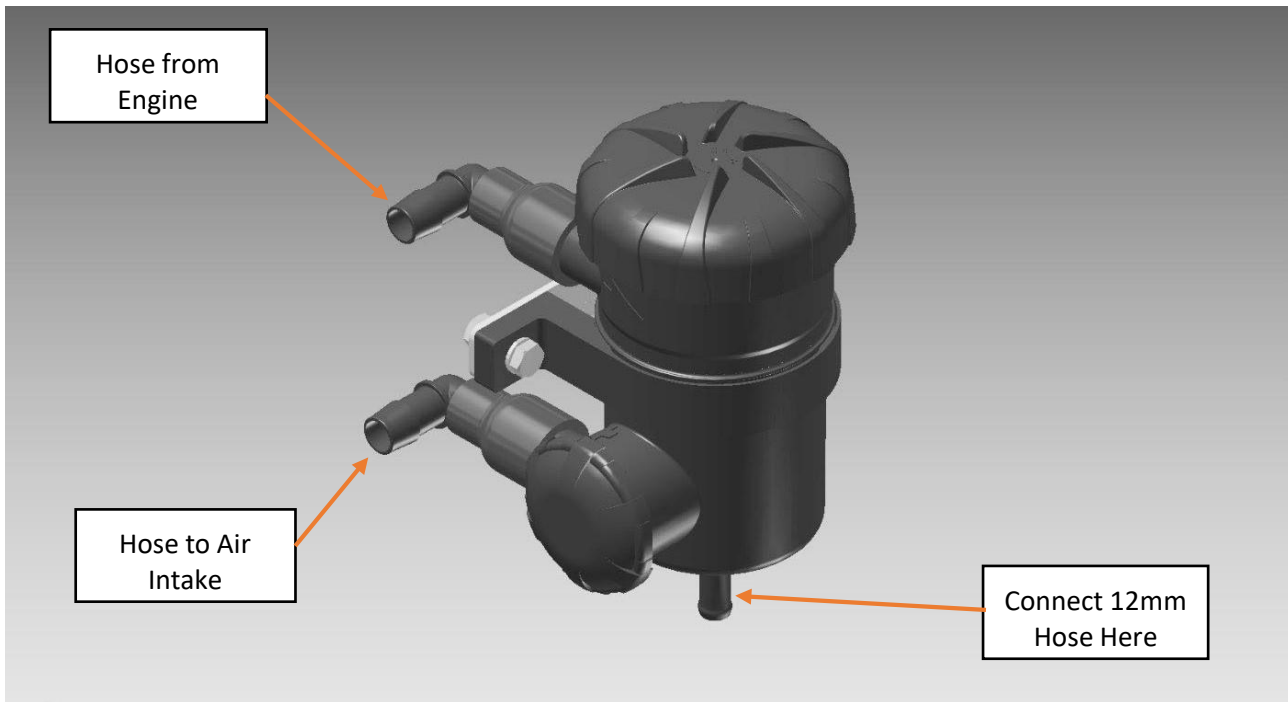

Pre-assembled ProVent® 200 with bracket – Please note ProVent® rotation in this image is correct, your ProVent® should come at the correct rotation in the box – if it is not, refer to the image on the last page of this installation guide.

6. Feed the 12mm Hose down the side of the engine bay, under the vehicle to an out of the way location, making sure it is clear of any suspension, driveline and exhaust components, fit the Tap hose tail into the hose and secure with a 12-20mm clamp.



Hose tail and tap assembly inserted into 12mm hose, secured with 12-20mm worm drive clamp

7. Use the supplied cable ties to secure the 12mm hose into the location required under the vehicle to prevent movement. Note: Leave a slight amount of slack in the line where the body and chassis join to prevent stretching the hose.
8. Make sure the tap position is closed and avoid placing the tap in a location in which it will fill with dirt and mud.



Left image – Tap Open.

Right image – Tap Closed.

1. Push the 16mm end of the 16-12mm joiner into the 75mm long 16mm (5/8") hose. Secure with 16mm spring clamp. Push the 12mm end into the 300mm long 12mm (1/2") hose. Secure with 12mm spring clamp. Mount the other end of the 75mm long 16mm (5/8") hose to the upper 16mm (5/8") 90° joiner fitting on the ProVent® 200 and secure with a 16mm spring clamp.
2. Mount the other end of the same hose assembly to the vacant fitting the original ventilation line was connected to on the valve cover. Secure in place with a 12mm spring clamp.

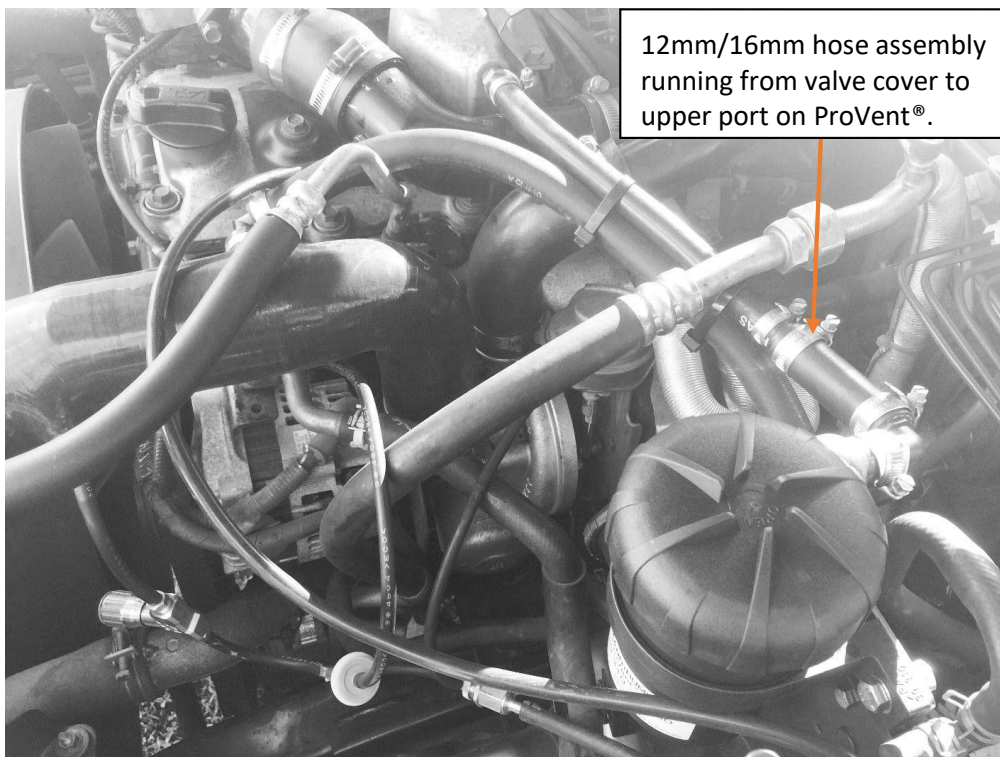

*Upper hose connected to inlet port on the ProVent® 200.
Please note old style clamps shown, kit comes with OEM style Spring Clamps.*

3. Mount one end of the 500mm 16mm (5/8") hose to the lower 16mm (5/8") 90° joiner fitting on the ProVent® 200.

4. Mount the other end of the 500mm 16mm (5/8") hose to the vacant fitting on the air intake piping hose connected to the hose running to the black box in front of the intercooler on the front passenger side.

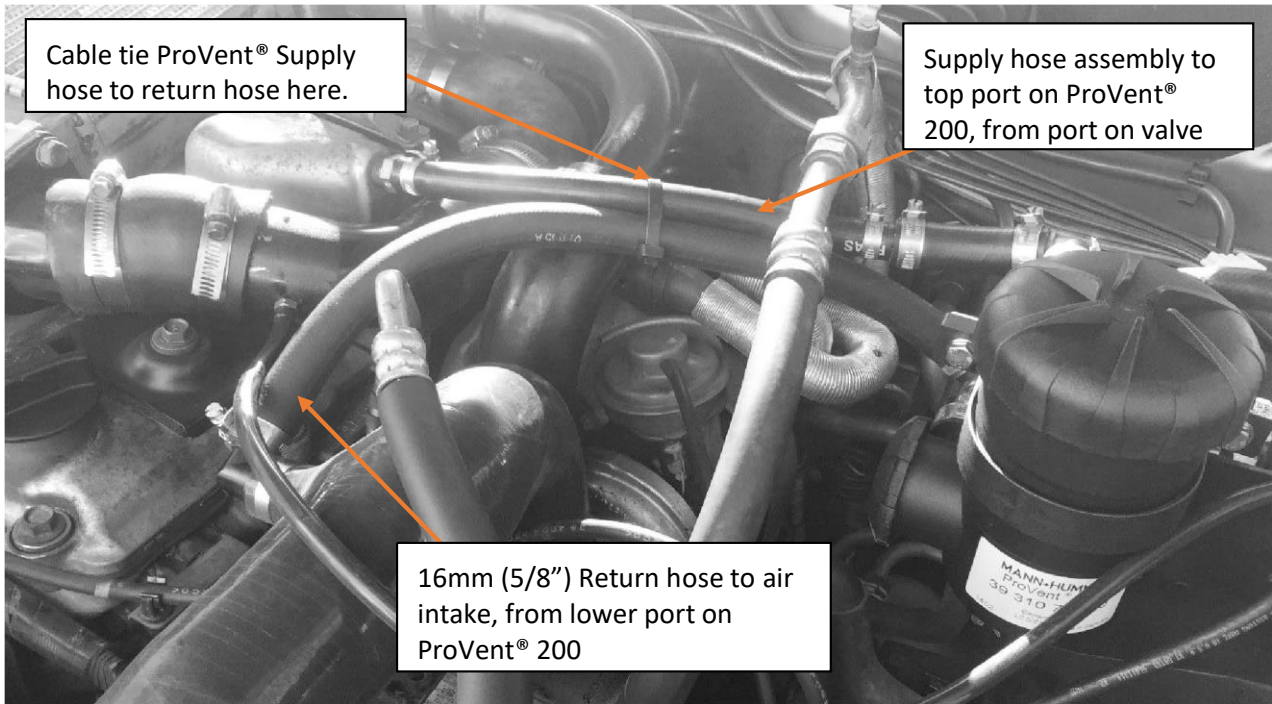

Hose configuration in GU Patrol ZD30 with ProVent® 200 installed – Note, the hoses need to be run underneath the air conditioning line. Please note old style clamps shown, kit comes with OEM style Spring Clamps.

End of Installation Guide

PV200 INTERNAL BYPASS VALVE SECTIONAL DIAGRAM

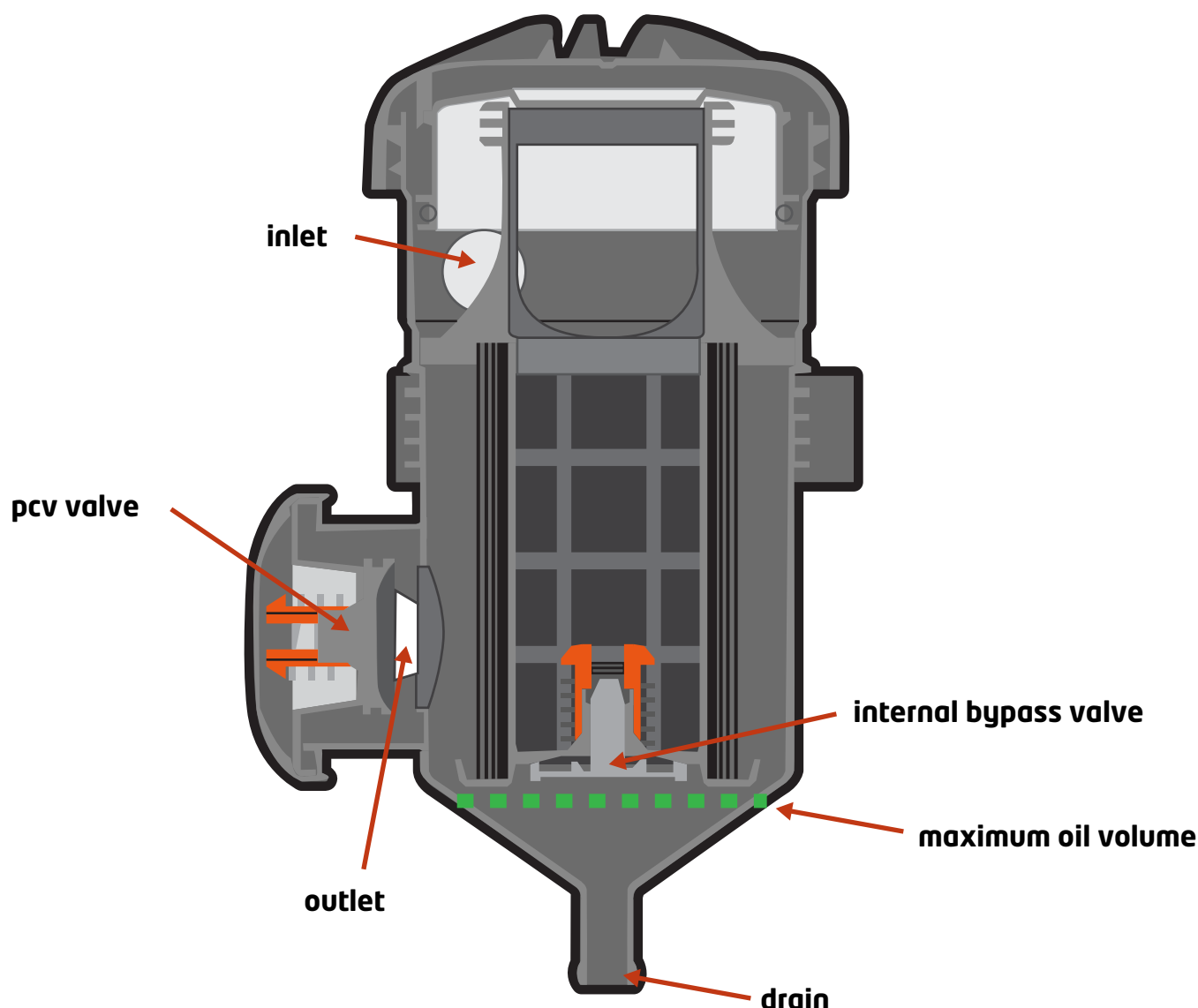

Due to the way the internally vented PV200 works, the PV200 must be drained regularly to ensure correct operation of the internal bypass valve. Failure to regularly draining/servicing the Catch Can may cause engine damage due to over pressurisation of the crankcase ventilation system.

The ■ ■ ■ in the diagram indicates the maximum permissible oil level. For the PV200 internal bypass valve to correctly operate the internal oil volume **MUST NOT** exceed the level indicated by the ■ ■ ■ shown in the diagram.

If the internal oil volume is to exceed the level indicated by the ■ ■ ■ shown in the diagram, the internal bypass valve cannot operate as designed due to it being submerged. This condition is likely to cause over pressurisation of the crankcase ventilation system and damaging the engine.

WARNING: Colder climates can cause increased condensation inside the Catch Can. This will fill the reservoir quicker than oil and will need to be drained regularly. Failure to do so could & can damaged the Catch Can or vehicle.

ProVent 200

The housing can (prior to installation) be turned in the holder in 30° steps around the longitudinal axis.

This enables the position "Inlet and outlet fitting to flange" to be flexibly adjusted to the installation situation.

- Remove the retaining clip (1) upward from the groove and turn the holder into the desired position.
- Press the holder together somewhat in the desired position and engage the retaining clip in the groove again
- Mount the holder in the vertical position. Recommended tightening torque for M8 screws: 10 Nm.
- Ensure sufficient strength of the screw and nut material.
- Connect the hoses to the inlet, outlet and oil return fittings (make sure a sufficient length of hose is pushed on) and secure with hose clamps (see Chap.4.2 and 4.3).
- Connect the oil return hose (and non-return valve if necessary) to the oil sump.
- To ensure proper functioning, the ProVent should be protected against dirt (mount splash guards if necessary).

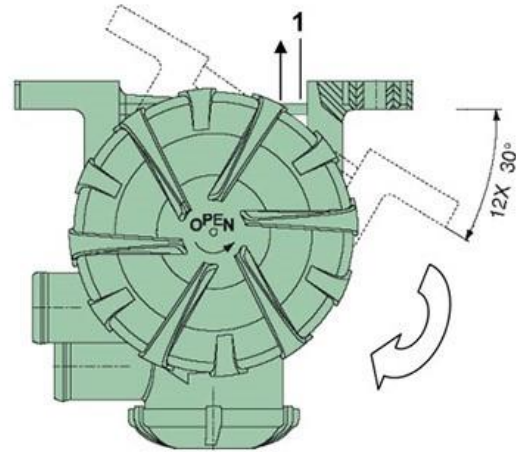

Fig. 5 Positions of outlet for ProVent 200

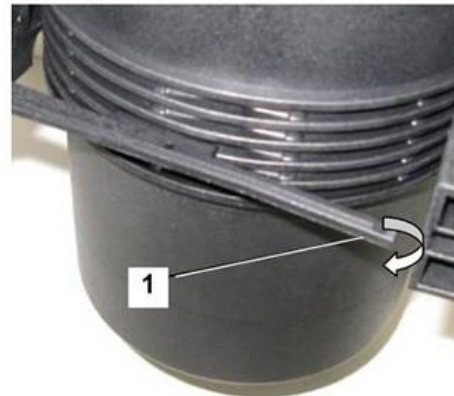

Fig. 6 Holder for ProVent 200