

Toyota Land Cruiser 70 Series 2012-2017 1VD-FTV Direction-Plus™ Fuel Manager Installation Guide

This document is to be used as a guide for the installation of the **Direction-Plus™ Fuel Manager Post-filter (PF640DPK)** to a **Toyota Land Cruiser 70 Series V8 Diesel 1VD-FTV (2012-2017)**. It is recommended that the installation of the product be carried out by a competent qualified mechanic.

Important Before Starting

- Ensure you have the correct tools to complete the fitment
- Read the instructions in full and familiarize yourself with the installation, before commencing any work

Maintenance / servicing

- It is recommended to drain the FUEL MANAGER element every 5,000 – 10,000km
- FUEL MANAGER element is to be replaced every 40,000km or as per your vehicles service interval

Included in the kit

- 1x Mounting Bracket
- 1x Fuel Manager 5M assembly
- 1x 8mm x 17mm washer
- 1x M8x16 bolt
- 1x 8mm spring washer
- 2x M10 Bolts
- 4x M10 Washers
- 2X M10 Nyloc Nuts
- 2x M6x16 Bolts
- 4x M6 Flat Washers
- 2x M6 Nyloc Nuts
- 1x 3m Length of 12mm Fuel Hose
- 2x 12mm Fuel Hose Clamps
- 2x Push on Straight 12mm
- 2x 1.5m Length of 35mm Heat Sleeve
- 2x 12mm Straight Push-Lock
- 1x Thread Sealant
- 4x Washers
- 2x Blanking Plugs
- 9x Cable Ties
- 1x Windscreen Label
- 1x Engine Bay Label

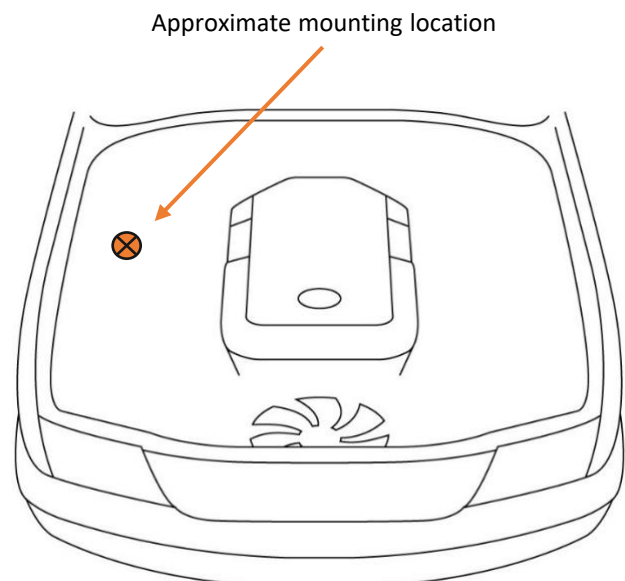

*Kit contents are subject to change based on component availability and/or refinement

Fuel Manager Post-Filter Normal Flow Header Connection

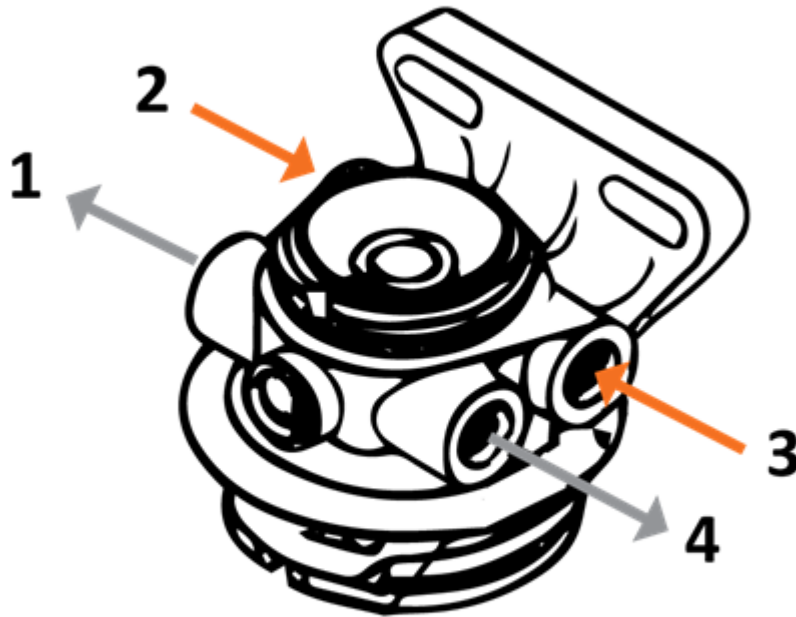

Ports 2 and 3 = INLET
Ports 1 and 4 = OUTLET

Installation Guide – Fuel Manager Post-Filter Kit

1. Using the supplied 10mm bolts, washers and nuts, mount the Fuel Manager Post-filter assembly filter to rear mounting location of the bracket
2. Install the two Push on straight 12mm to the filter head, so that when the filter is mounted on the bracket, they will both be facing toward the rear of the vehicle
3. Install the two blanking plugs into the remaining ports.

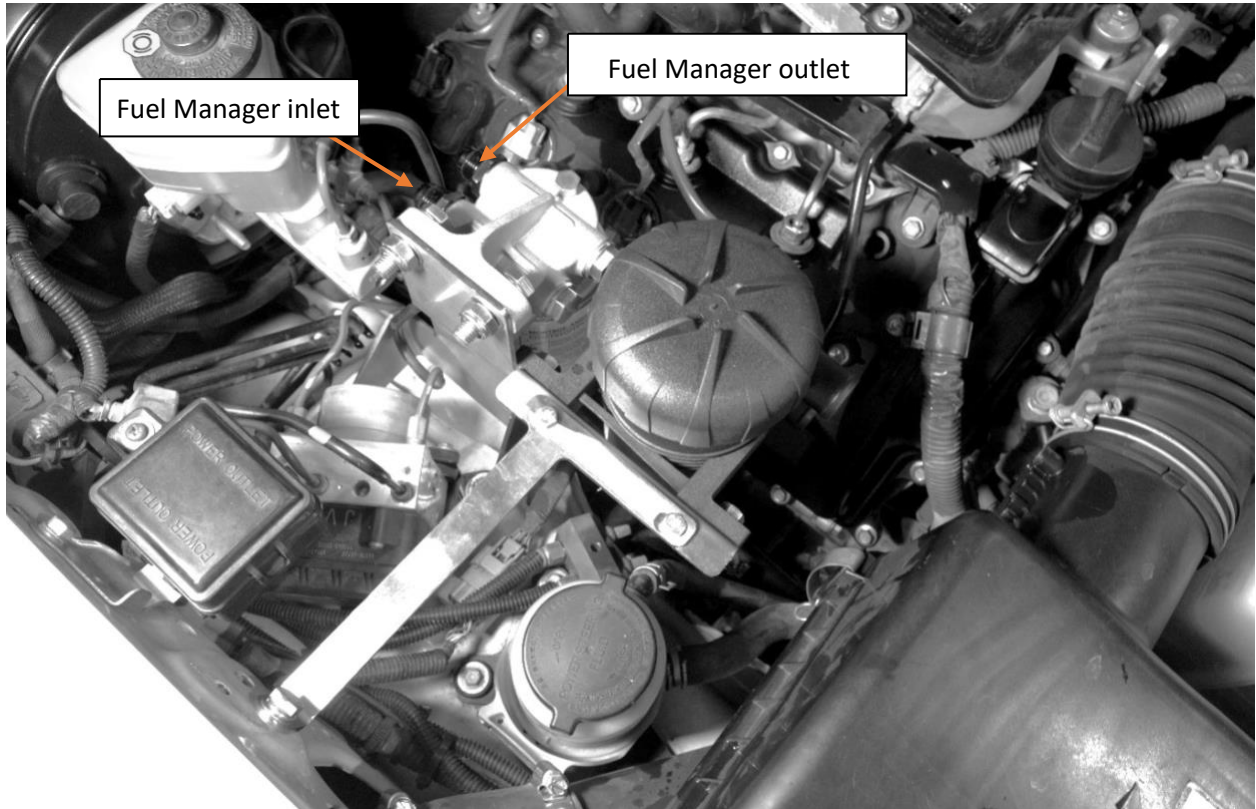

4. Lubricate the barbed end of one push-lock fitting and the inside portion of the hose to be fitted with a push-lock fitting with diesel fuel or WD40
5. Insert the barbed end of one push-lock fittings into the pre-lubricated end of the hose. Ensuring that the hose stops firmly against the inside of the bell cover.
6. Install a length of the supplied heat shield over the hose – trim to length if required
7. With the assembled hose, screw the push-lock fitting on to the inlet port of the Post-filter. Routing the hose along the firewall, Connect the other end of the same hose to the outlet port of the factory filter and secure using a supplied 12mm fuel hose clamp

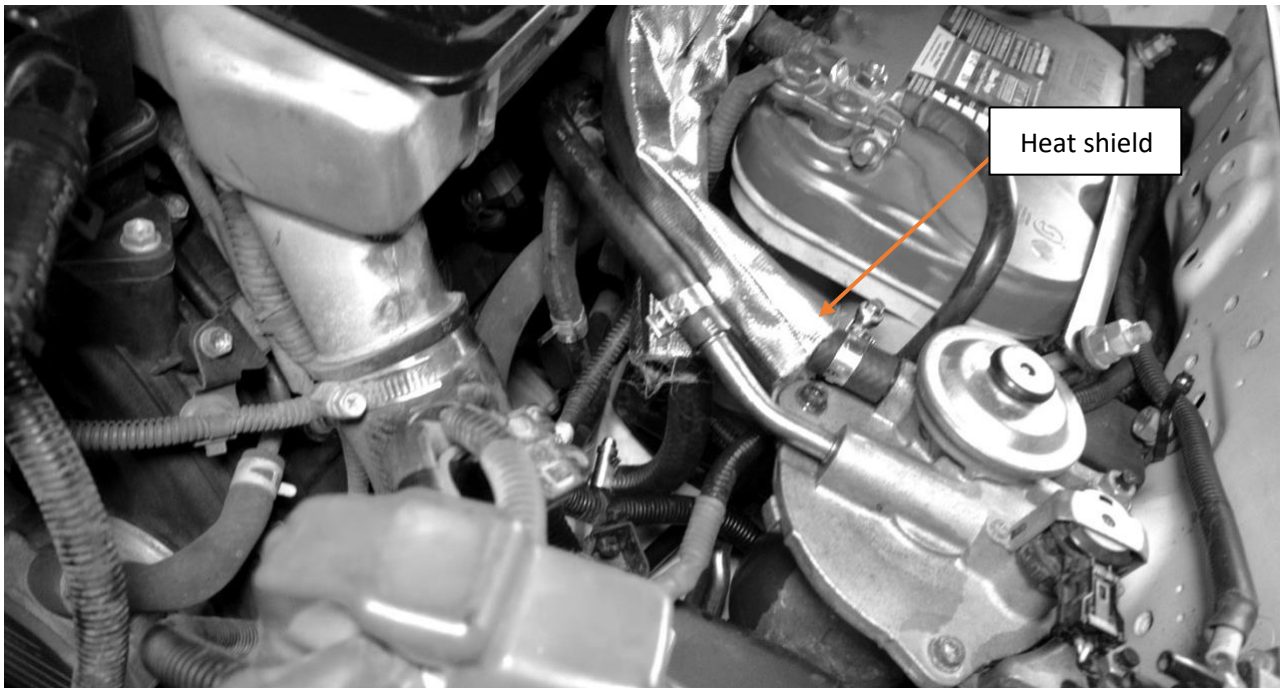



8. Lubricate the barbed end of the remaining push-lock fitting and the inside portion of the remaining hose to be fitted with a push-lock fitting with diesel fuel or WD40
9. Insert the barbed end of the remaining push-lock fittings into the pre-lubricated end of the hose. Ensuring that the hose stops firmly against the inside of the bell cover
10. Install a length of the supplied heat shield over the hose – trim to length if required
11. With the now assembled hose, screw the push-lock fitting on to the outlet port of the Post-filter
12. Routing the hose along the firewall, measuring the hose in place between the outlet port of Post-filter and the inlet of the common rail supply pump
13. Cut the hose to length and secure with the supplied hose clamp.
14. Using the supplied nylon cable ties, secure any loose hose from rubbing on any other components
15. Bleed the fuel system by pumping the hand primer on the factory filter until firm – **NOTE: it is easier to prime the system if the Fuel Manager element is filled with clean diesel before using the hand primer.**
16. Start vehicle and run the vehicle, whilst checking all connections for leaks

End of Fuel Manager Installation Guide