



Isuzu D-MAX / MUX 4JJ1 2013-2017 Dual Battery Direction-Plus™ Post-Filter Kit Installation Guide

This document is to be used as a guide for the installation of the **Direction-Plus™ Fuel Manager™ Post-filter Kit (PF631DPK)** to an **Isuzu D-MAX / MUX 4JJ1 2013-2017 dual battery**. It is recommended that the installation of the product be carried out by a competent qualified mechanic.

Important before starting

- Ensure the engine bay is clean and free from contaminants
- The fuel manager filter head has direction arrows indicating the direction of flow
- You have the correct tools to complete the fitment
- Read the instructions in full and familiarize yourself with the installation before commencing any work

Kit contents

- 2x NPT Straight - 12mm
- 2x Push On Straight - 12mm
- 2x DP733-04 - NPT Plug
- 2x FMC12 - Clamp 12mm
- 1x 1.5m DFL12 - 12mm Hose
- 1x 2 Bolts 2 Nuts 4 Washers
- 1x Loctite 567 Thread Sealant - 6ml
- 1x Element Assembly 2m - 3.6"
- 1x Windscreen Label
- 1x FM Engine Bay Label
- 1x Bracket – D-Max/MU-X

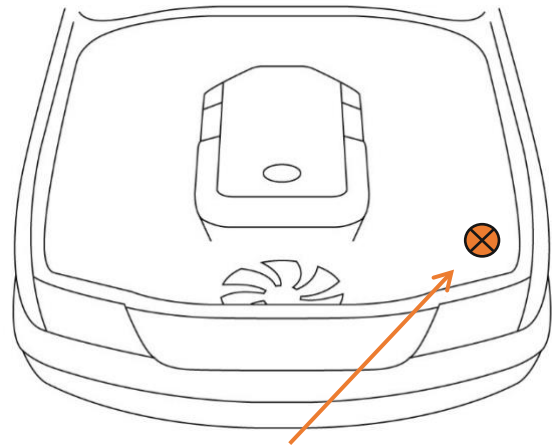

Post filter mounting location

*Kit contents are subject to change based on component availability and/or refinement

Fuel Manager Post-Filter Normal Flow Header Connection

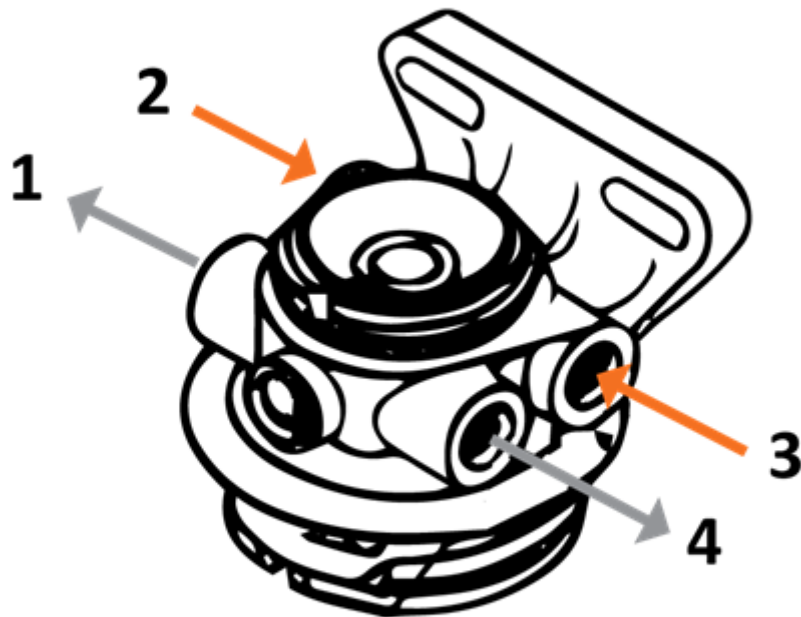

Ports 2 and 3 = INLET
Ports 1 and 4 = OUTLET



Installation Guide

1. Remove the 10mm bolt that secures the battery retention bracket to the guard just behind the passenger side headlight. Retain this bolt as it will be reused
2. Remove the 10mm bolt securing one side of the power steering reservoir that is in line with the ISUZU build plate on the radiator support panel. Retain this bolt as it will be used later.
3. Place the Post-filter mounting bracket into its mounting location so that the flange is facing up. The horizontal tab on the mounting bracket will need to be slipped underneath the battery retention bracket
4. Loosely re-install the 10mm bolt that was removed from the battery retention bracket
5. Line up the other end of the Post-filter bracket with the bolt hole for the power steering reservoir mounting bracket. Re-install the 10mm bolt that was previously removed and tighten
6. Tighten the 10mm bolt that secures the battery retention bracket
7. Mount the Post-filter assembly to the mounting bracket using the 2 x 10mmx30mm bolts, 4 x 10mm flat washers, 2 x 10mm nyloc nuts.
8. Install the NPT adapters, using a small amount of the supplied thread sealant to the inlet and outlet ports that are facing towards the rear of the vehicle.
9. Install the NPT plugs into the two remaining ports facing towards the front of the vehicle, using a small amount of the supplied thread sealant and tighten.
10. Lift the factory fuel filter out of the factory mounting bracket and let sit to one side.
11. Lubricate the barbed end of one push-lock fitting and the inside portion of the hose to be fitted with a push-lock fitting with diesel fuel or WD40
12. Insert the barbed end of one push-lock fitting into the pre-lubricated end of the hose. Ensuring that the hose stops firmly against the inside of the bell cover.
13. With the assembled hose, screw the push-lock fitting on to the inlet port of the Post-filter. Connect the other end of the same hose to the outlet port of the factory filter and secure using a supplied 12mm hose clamp
14. Lubricate the barbed end of the remaining push-lock fitting and the inside portion of the remaining hose to be fitted with a push-lock fitting with diesel fuel or WD40
15. Insert the barbed end of the remaining push-lock fitting into the pre-lubricated end of the hose. Ensuring that the hose stops firmly against the inside of the bell cover.
16. With the now assembled hose, screw the push-lock fitting on to the outlet port of the Post-filter.



17. Measuring the hose in place between the outlet port of Post-filter the inlet of the common rail supply pump with the supplied hose clamp.
18. Refit the factory fuel filter back into its mounting bracket.
19. Apply a small amount of LOCTITE thread sealant to the two black NPT plugs and install them into the two remaining ports in the Post-filter head.
20. Using the supplied nylon cable ties, secure any loose hose from rubbing on any other components
21. Bleed the fuel system by pumping the hand primer on the factory filter until firm
22. Start vehicle and run the vehicle, whilst checking all connections for leaks

END OF GUIDE