



Mitsubishi Pajero 2006 - current 4M41 Direction-Plus™ Post-Filter Kit Installation Guide

This document is to be used as a guide for the installation of the **Direction-Plus™ Fuel Manager™ Post-filter Kit (PF607DPK)** to a **Mitsubishi Pajero 2006 – current with a 4M41 engine**. It is recommended that the installation of the product be carried out by a competent qualified mechanic.

Important before starting

- Ensure the engine bay is clean and free from contaminants
- The fuel manager filter head has direction arrows indicating the direction of flow
- You have the correct tool to complete the fitment
- Read the instructions in full and familiarize yourself with the installation before commencing any work

Kit contents

2x 1/4" NPT STRAIGHT
1x 10MM 2 BOLTS 2 NUTS 4 WASHERS
1x 8MM X 17MM ZINC
1x BRACKET - PAJERO NS
9x CABLE TIE 280 X 4.8 (UV)
4x DFL10 - FUEL LINE RUBBER (10MM)
2x NPT PLUG
1x FM ENGINE BAY LABEL
1x FM100 2 MICRON FILTER ASSY
2x HOSE CLAMP - 10MM
1x LOCTITE 567 THREAD SEALANT - 6ML
1x NYLOC NUT M8
2x PUSH ON 90 DE
1x WINDSCREEN LABEL

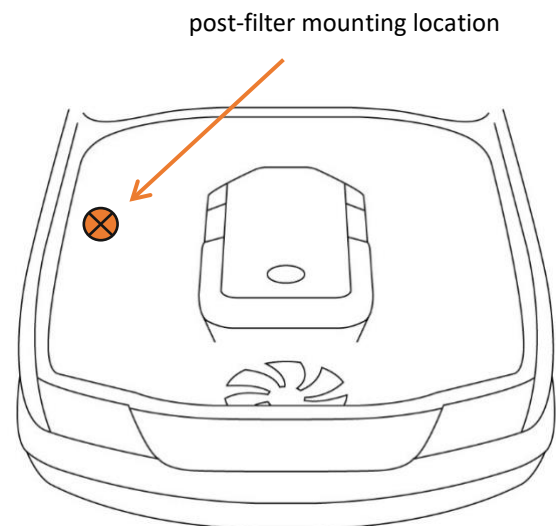

*Kit contents are subject to change based on component availability and/or refinement

Fuel Manager Post-Filter Normal Flow Header Connection

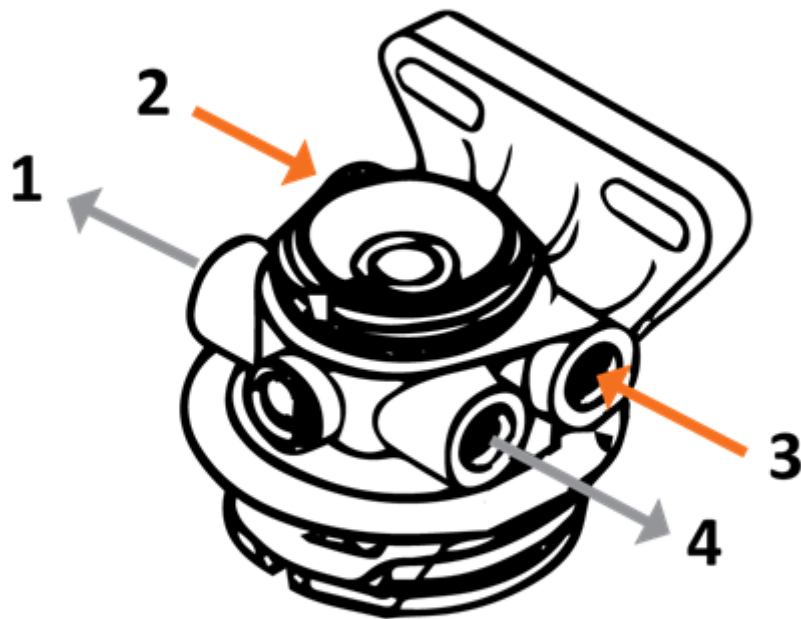

Ports 2 and 3 = INLET
Ports 1 and 4 = OUTLET



Installation Guide

1. Disconnect the wire from the anti-theft horn located on the driver's side inner guard. Note that later models of the Pajero may not have this horn, in which case disregard these parts of the guide.
2. With a small screwdriver or similar tool, release the locking tab on the ABS relay holder, remove it from the mounting bracket and place it to one side.
3. Remove the bolt and nut that secures the ABS relay bracket to the inner guard.
4. Remove the ABS relay bracket and if fitted the horn bracket as well.
5. Dismantle the two-piece horn bracket, only the part that the horn is attached to will be reused
6. You will need to modify the ABS relay bracket. Bend the tab that holds the ABS relays backwards (as if it were mounted in the vehicle) approximately 45°
7. Insert the two 10mm bolts into the Post-filter mounting bracket from behind, so that when the bracket is mounted the bolt heads will be between the bracket and the guard with the thread pointing inwards towards the engine.
8. Slide the Post-filter mounting bracket onto the two studs on the inner guard
9. Secure the mounting bracket by using one 8mm nut on the forward most stud only
10. Refit the modified ABS relay bracket and secure with one 8mm nut
11. Refit the horn and horn bracket using one 8mm bolt
12. Refit the ABS relays to the ABS relay mounting bracket
13. Reconnect the anti-theft horn wire
14. Mount the Post-filter assembly to the mounting bracket using the previously installed 10mm bolts, and the remaining two 10mm nyloc nuts and washers.
15. Using a small amount of the supplied Loctite thread sealant install the two black NPT plugs into the two ports on the Post-filter housing that are facing towards the rear of the vehicle
16. Using a small amount of the supplied Loctite thread sealant install the two NPT adapters into the two ports on the Post-filter housing that are facing toward the front of the vehicle
17. Measure and cut the supplied length of 10mm fuel line in half
18. With both lengths of 10mm fuel hose, Lubricate the inside portion of one end using diesel fuel or WD40
19. Using both supplied 10mm 90° push-lock fittings, lubricate the barbed end with diesel fuel or WD40
20. Install both 10mm straight push-lock fittings into the pre-lubricated end of each 10mm fuel hose, ensuring that the hose stops firmly against the inside of the bell cover of each fitting



21. Remove the fuel hose from the factory fuel filter outlet, this will be connected to the outlet of the Post Filter
22. With one of the assembled 10mm fuel hoses connect the push-lock fitting to the inlet of the Post-filter assembly.
23. Route the 10mm fuel hose connected from the inlet of the Post-filter, along the top of the fire wall and across to the outlet of the factory fuel filter.
24. If required cut the hose to length (remember to leave enough length on the hose so that it can be safely secured later)
25. Connect existing fuel line (connected to engine) to outlet of Post Filter using one of the assembled 10mm fuel hoses
26. Using the supplied nylon cable ties carefully secure both 10mm fuel hoses along the top of the fire wall, ensuring they are not kinked or can come in contact with any hot components.
27. Bleed the fuel system by temporarily removing the hose from the outlet of the post filter.
28. Place a small container under the outlet to catch diesel fuel
29. Pump the primer button (black button, located on top of the factory fuel filter) until a clear stream of fuel flows from the outlet pipe
30. Refit the hose and to the fuel filter and continue pumping the primer button till it is firm.
31. Remove any loose tools from the work area
32. Start the vehicle and allow run for 2-3 minutes whilst checking for any possible leaks.

END OF GUIDE