



## Nissan Navara ST-X 550

### Direction-Plus™ Post-Filter Kit Installation Guide

This document is to be used as a guide for the installation of the **Direction-Plus™ Fuel Manager™ Post-filter Kit (PF606DPK)** to a **Nissan Navara ST-X 550**. It is recommended that the installation of the product be carried out by a competent qualified mechanic.

#### Important before starting

- Ensure the engine bay is clean and free from contaminants
- The fuel manager filter head has direction arrows indicating the direction of flow
- You have the correct tool to complete the fitment
- Read the instructions in full and familiarize yourself with the installation before commencing any work

#### Kit contents

1x 2 BOLTS 2 NUTS 4 WASHERS  
2x 90 DEG 1/4-6 FITTING 10MM  
2x 9.89 STRAIGHT 8MM BARB  
2x BOLT - 6X25MM ZINC  
1x BRACKET - NAVARA 550  
3x DFL10 - FUEL LINE RUBBER (10MM)  
2x DP733-04 - NPT PLUG  
1x FM ENGINE BAY LABEL  
1x FM100 2 MICRON FILTER ASSY  
2x HOSE CLAMP - 10MM  
1x LOCTITE 567 THREAD SEALANT - 6ML  
2x NUT - NYLOC 6MM  
2x PUSH ON STRAIGHT - 10MM  
2x WASHER - 6MM  
1x WINDSCREEN LABEL

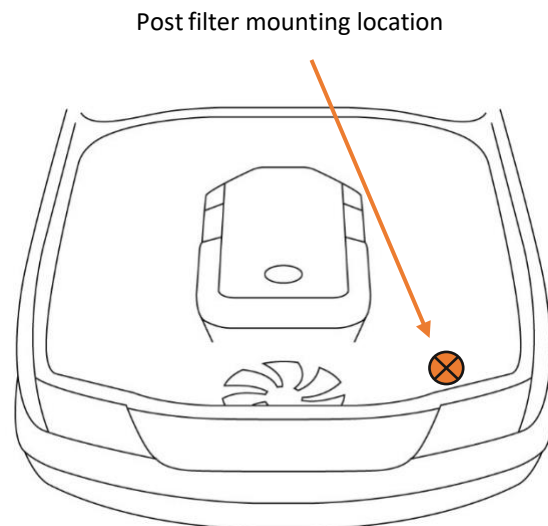

\*Kit contents are subject to change based on component availability and/or refinement

## Fuel Manager Post-Filter Normal Flow Header Connection

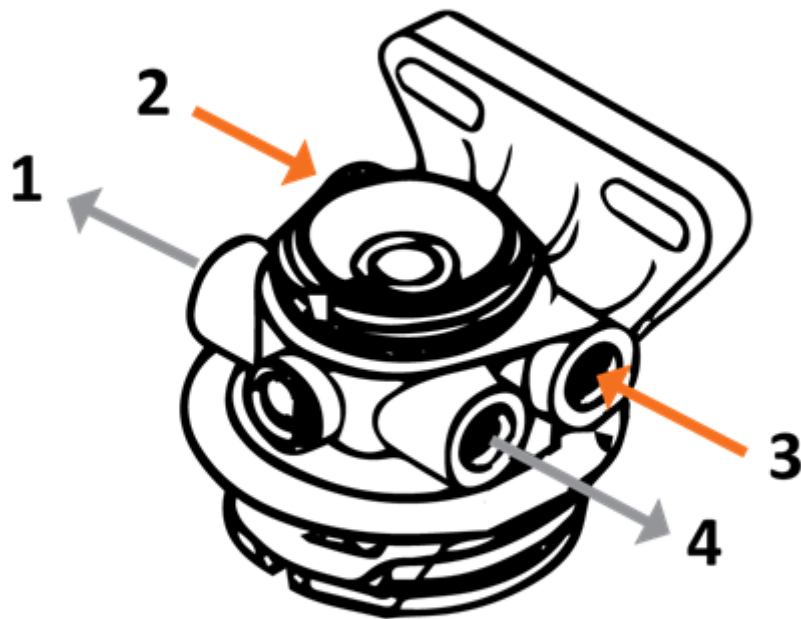

**Ports 2 and 3 = INLET**  
**Ports 1 and 4 = OUTLET**

### Note

In addition to the contents in this kit you will require a 1 litre container suitable for catching fuel and the Nissan fuel priming tool that was supplied with your vehicle from the factory. Refer to your owner's manual (section 8-12) for the location of the fuel priming tool.



## Installation Guide

1. Remove the radiator mounting bolt from the top, passenger side of the radiator
2. Place the Post-filter mounting bracket into the mounting location and loosely secure it in place by reinstalling the radiator mounting bolt. **Do not tighten**
3. Use the two supplied 6mm bolts, washers and nyloc nuts to loosely secure the upright portion of the mounting bracket. One mounting hole is located toward the top of the mounting bracket and the second mounting hole is located towards the bottom of the mounting bracket. **Do not tighten** the two 6mm bolts
4. Secure the mounting bracket by first tightening the radiator mounting bolt, then tighten the two 6mm mounting bolts
5. Hold the Post-filter assembly so that the mounting bracket is facing away from you
6. Using a small amount of the supplied Loctite thread sealant install one of the NPT 90° adapter into the right-hand inlet port as indicated by the direction arrow. Ensure that when the fitting is tightened that it is facing towards you.
7. Using a small amount of the supplied Loctite thread sealant Install the second NPT 90° adapter into the left-hand outlet port as indicated by the directional arrow. Ensure that when the fitting is tightened that it is facing towards you.
8. Measure and cut the supplied 10mm fuel hose into two 1 meter lengths
9. With both 1 meter lengths of 10mm fuel hose, Lubricate the inside portion of one end using diesel fuel or WD40
10. Using both supplied 10mm straight push-lock fittings, lubricate the barbed end with diesel fuel or WD40
11. Install both 10mm straight push-lock fittings into the pre-lubricated end of each 10mm fuel hose, ensuring that the hose stops firmly against the inside of the bell cover of each fitting.
12. Connect and tighten both fuel hose assemblies to the inlet and the outlet fittings on the Post-filter assembly.
13. Place the Post-filter assembly into its mounting location by lowering it into position, at the same time you will need to feed both fuel hoses between the inner guard and the airbox towards the factory fuel filter.
14. Once the Post-filter assembly is in position and the fuel hose is routed, secure the Post-filter assembly to the mounting bracket with the supplied 10mm bolts, washers and nyloc nuts.
15. Take the nylon 9.89mm female quick disconnect fitting installed into the 10mm fuel hose from the inlet port of the Post-filter assembly and connect it to the outlet barb on the factory fuel filter.
16. Insert the other 9.89mm female quick disconnect fitting in the 10mm hose coming from the outlet port of the Post-filter assembly and secure with a supplied 10mm hose clamp



17. You will now need to bleed the fuel system. (refer to the owner's manual, section 8-12)
18. Located behind the rear seat near the jack will be a silver bag containing a bulb type primer used for priming the fuel system.
19. Remove the engine cover by lifting the front most part of the engine cover up and sliding it to the rear of the engine.
20. Connect the remaining of the supplied 10mm fuel hose to the barbed fitting on the bulb of the priming tool
21. Remove the plastic blanking cover from the fuel bleed port as illustrated in the owner's manual
22. Connect the long tube of the primer tool to the fuel bleed port and place the end of the 10mm fuel hose into a 1 litre container
23. Pump the primer bulb a clear stream of fuel can be seen through the tube of the priming tool.
24. Once the fuel system is primed remove the priming tool and refit the plastic blanking cover to the fuel bleed port.
25. Refit the engine cover in reverse to the way you removed it
26. Start the vehicle and allow run for 2-3 minutes whilst checking for any possible leaks.

**END OF INSTRUCTION**