



Holden Colorado 2.8 Direction-Plus™ Post-Filter Kit Installation Guide

This document is to be used as a guide for the installation of the **Direction-Plus™ Fuel Manager™ Post-filter Kit (PF602DPK)** to a **Holden Colorado 2.8 and Colorado 7**. It is recommended that the installation of the product be carried out by a competent qualified mechanic.

Important before starting

- Ensure the engine bay is clean and free from contaminants
- The fuel manager filter head has direction arrows indicating the direction of flow
- You have the correct tool to complete the fitment
- Read the instructions in full and familiarize yourself with the installation before commencing any work

Kit contents

2x 1/4" NPT STRAIGHT - 10MM 11.8 STR 10MM 1x
1x BARB
1x 2 BOLTS 2 NUTS 4 WASHERS
1x 9.49 90 DEG 10MM BARB
1x BOLT - 6X25MM ZINC
1x BRACKET - COL 2.8
4x DFL10 - FUEL LINE RUBBER (10MM)
2x DP733-04 - 1/4 "NPT PLUG
1x ELEMENT ASSEMBLY 30M - 3.6"
1x END 11.8 STR 12MM BARB
1x END 9.49 STR 8MM BARB
2x END 9.49 STR 10MM BARB
1x FM ENGINE BAY LABEL
1x FM100 30 MICRON FILTER ASSY
1x HOSE CLAMP – 2x 10MM
1x LOCTITE 567 THREAD SEALANT - 6ML
2x PUSH ON 90 DEG - 10MM
1x WASHER - 6MM
1x WINDSCREEN LABEL

Postfilter mounting location

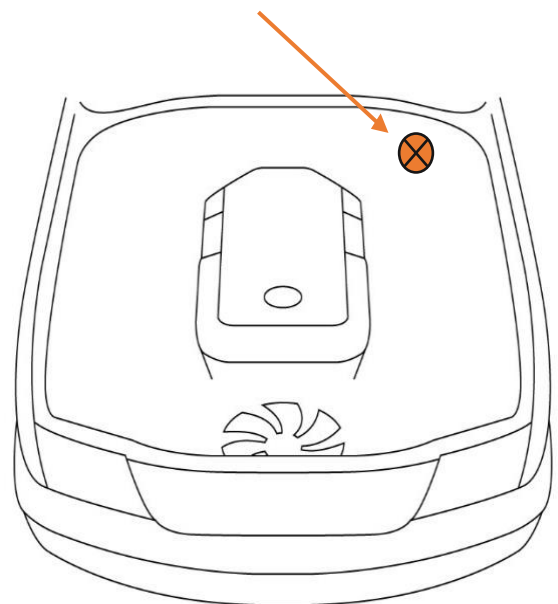

*Kit contents are subject to change based on component availability and/or refinement

Fuel Manager Post-Filter Normal Flow Header Connection

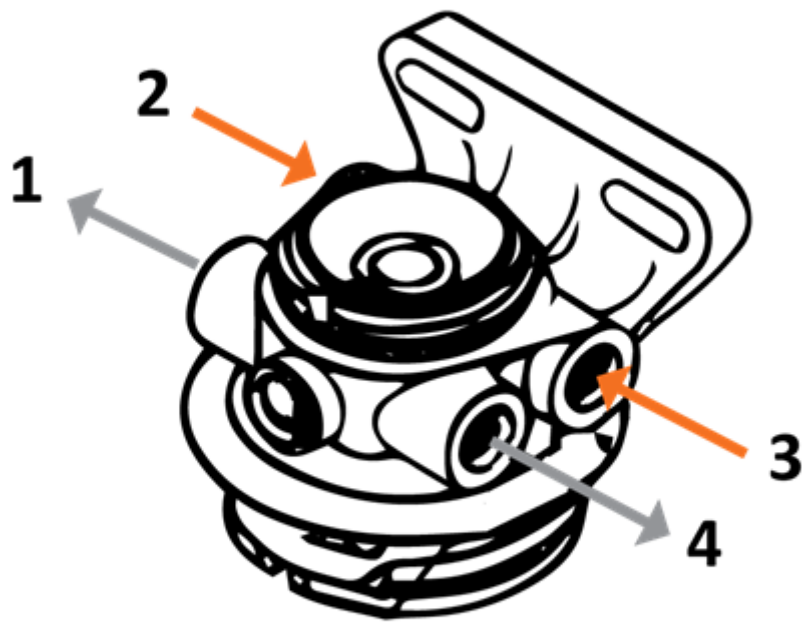

Ports 2 and 3 = INLET
Ports 1 and 4 = OUTLET

Note

The supplied nylon 11.8mm quick disconnect fittings may be required for utility applications. The nylon 11.8mm male and female straight quick connects are connected to the fuel line that comes from the outlet of the factory fuel tank to the inlet hose on the Pre-filter. **May not be required on Post Filter applications.**

The nylon 11.8mm male quick connect is not required for the Colorado 7 as the fitting is already installed from factory.



Installation Guide

1. Remove the 8mm bolt on the bottom of the ECU bracket located against the passenger side fender. Retain this bolt as it will be reused.
2. Place the Post-filter mounting bracket in the engine bay, on the passenger side corner against the firewall
3. With supplied 6mm bolt and reusing the original 8mm bolt secure the base of the bracket, fixing the 6mm bolt to the steel bracket located on the inner guard.
4. Mount the FM100 Post-filter assembly on to the mounting bracket, using the supplied 10mm bolts, nyloc nut and washers.
5. Install the two NPT adaptors into the filter head ports facing towards the center of the vehicle using small amount of LOCTITE thread sealant.
6. Install the two NPT blanking plugs into the two remaining ports facing towards the outside of the vehicle using a small amount of LOCTITE thread sealant.
7. Before cutting the supplied 10mm hose, you will need to install one of the supplied black 90° push-lock fittings.
8. Lubricate the barbed end of one push-lock fitting and the inside portion of the hose to be fitted with a push-lock fitting with diesel fuel or WD40
9. Insert the barbed end of one push-lock fittings to the pre-lubricated end of the hose. Ensuring that the hose stops firmly against the inside of the bell cover.
10. With the assembled hose, screw the 90° push-lock fitting on to the inlet of the Post-filter as indicated with the directional arrows located on the top of the ports.
11. Locate the factory filter on the passenger side, under the vehicle mounted to the chassis.
12. Route the hose along the underside of the vehicle back to the Outlet port of the factory filter.
13. Cut the fuel hose to length at the Outlet port of the factory fuel filter. Keep the excess 10mm hose as this will be used later.
14. Install one of the supplied nylon 9.49mm male straight quick connectors to the now cut hose and secure with one of the supplied 10mm hose clamps.
15. Disconnect the factory fuel line from Outlet of the factory fuel filter and install the 9.49mm female straight quick connect and secure with a 10mm hose clamp.
16. Connect the nylon male and female 9.49mm straight quick connects
17. Connect the factory fuel line to the outlet of the FM100 Post-filter
18. Using the supplied nylon cable ties, secure the hoses to prevent kinking and abrasion.



19. Now bleed the fuel system by turning the ignition to the "ON" position (do not attempt to start the engine) wait 60 seconds for the fuel system to bleed.
20. Switch the ignition "OFF", then turn the ignition to "ON" and then start the vehicle [™]
21. Allow the engine to run for 2-3 minutes, whilst checking all connections for possible fuel leaks