



Direction-Plus Fuel Manager Pre-Filter + Provent Ultimate Catch Can Kit Installation Guide for Ford Ranger PXIII

ProVent Ultimate Catch Can Installation Guide

This document is to be used as a guide for the installation of the **Direction-Plus™ ProVent Ultimate Catch Can Kit to a Ford Everest (2018-2022), Ranger PXIII Bi-Turbo (2019-2022) and Ranger Raptor (2018-2021).**

It is recommended that the installation of the product be carried out by a competent qualified mechanic.

Important before starting

- Ensure the engine bay is clean and free from contaminants
- The filter head has direction arrows indicating the direction of flow
- You have the correct tools to complete the fitment
- Read the instructions in full and familiarize yourself with the installation before commencing any work

Included in the kit

- 1 x Mann + Hummel ProVent 200
- 1 x Mounting Bracket A
- 1 x Mounting Bracket B
- 2 x 25mm – 19mm reducers
- 1 x 25mm – 16mm reducer
- 1 x 1000 mm of 19mm Hose
- 1 x 500mm of 19mm hose
- 1 x 65mm of 19mm Hose
- 3 x 19mm 90° Joiners
- 1 x 19mm-16mm straight connector
- 7 x 19mm Clamps
- 3 x 25mm clamps
- 4 x Cable Ties
- 1 x M8x16 Bolt
- 2 x M8 Flat Washers
- 1 x M8 Stainless Steel Nut
- 2 x M8x25 Bolts
- 4 x M8 Flat Washers
- 2 x M8 Stainless Steel Nuts
- 1 x 1000mm of 12mm Hose
- 1 x Drain Tap Assembly
- 2 x 18-20mm Hose Clamps

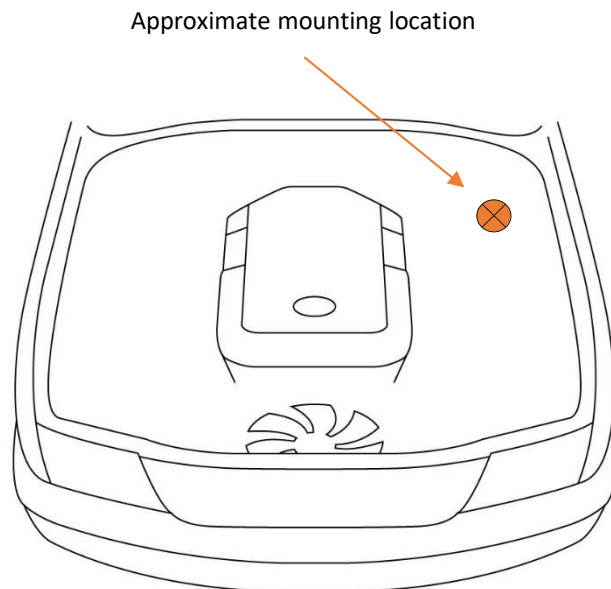

Kit contents are subject to change based on availability

ProVent Ultimate Catch Can Installation Guide

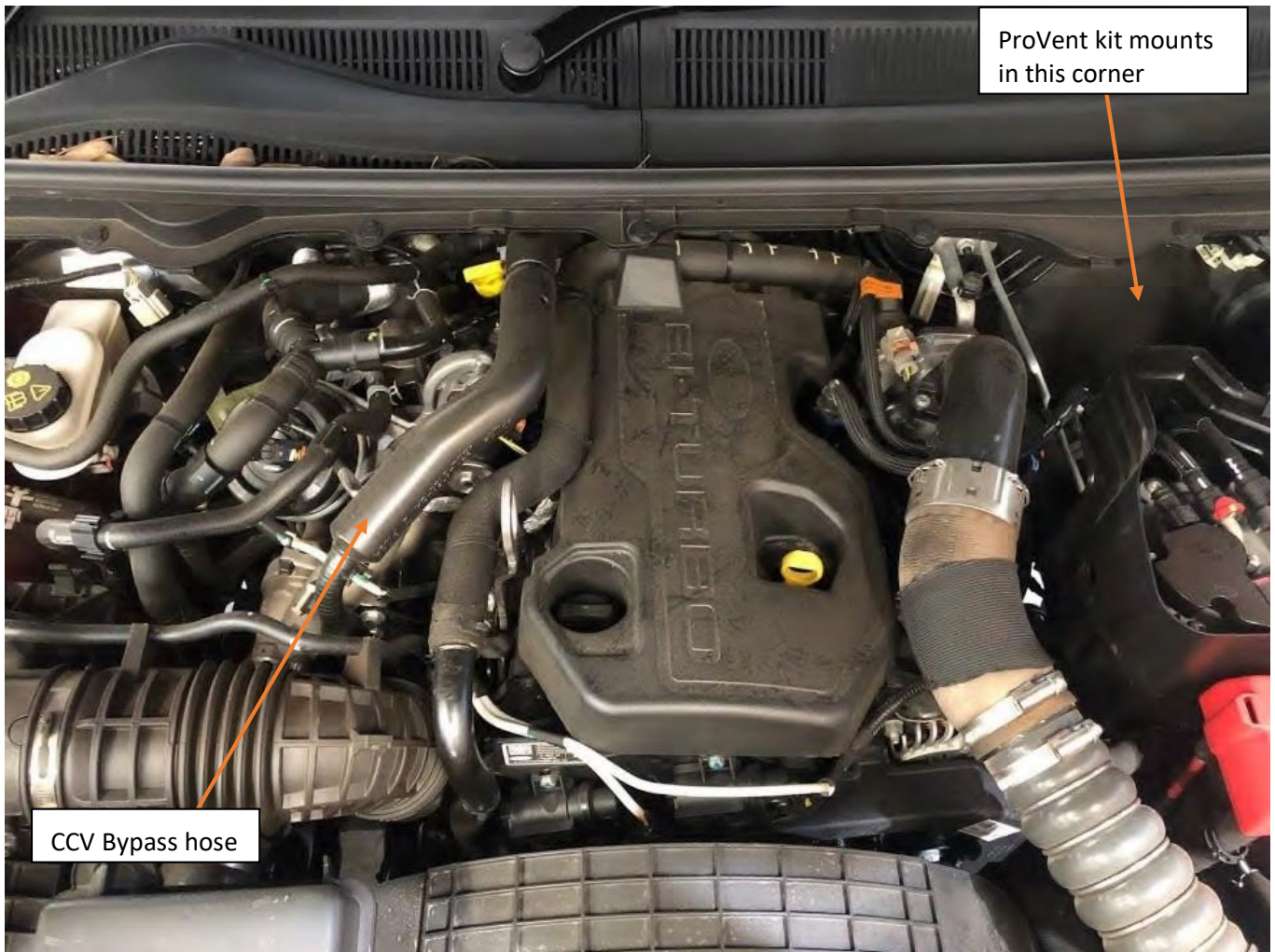

Ranger PXIII Engine Bay – Overall View

1. Locate the factory bypass hose which runs from the valve cover on the driver's side of the engine to the intake pipe just after the concertina section. The hose is about 500mm in length and has a few bends in it. Once located, remove this hose from the vehicle. On both ends of the CCV pipe there is a sliding collet which needs to be pushed back up into the connector to release the pipe
2. Locate the 2x M6 nuts located on the factory fuel filter bracket. They will need to be removed to allow fitment of the new bracket. You will also need to remove the bolt that retains the ABS unit nearby, the brace secures to this and the factory bolt gets reused.

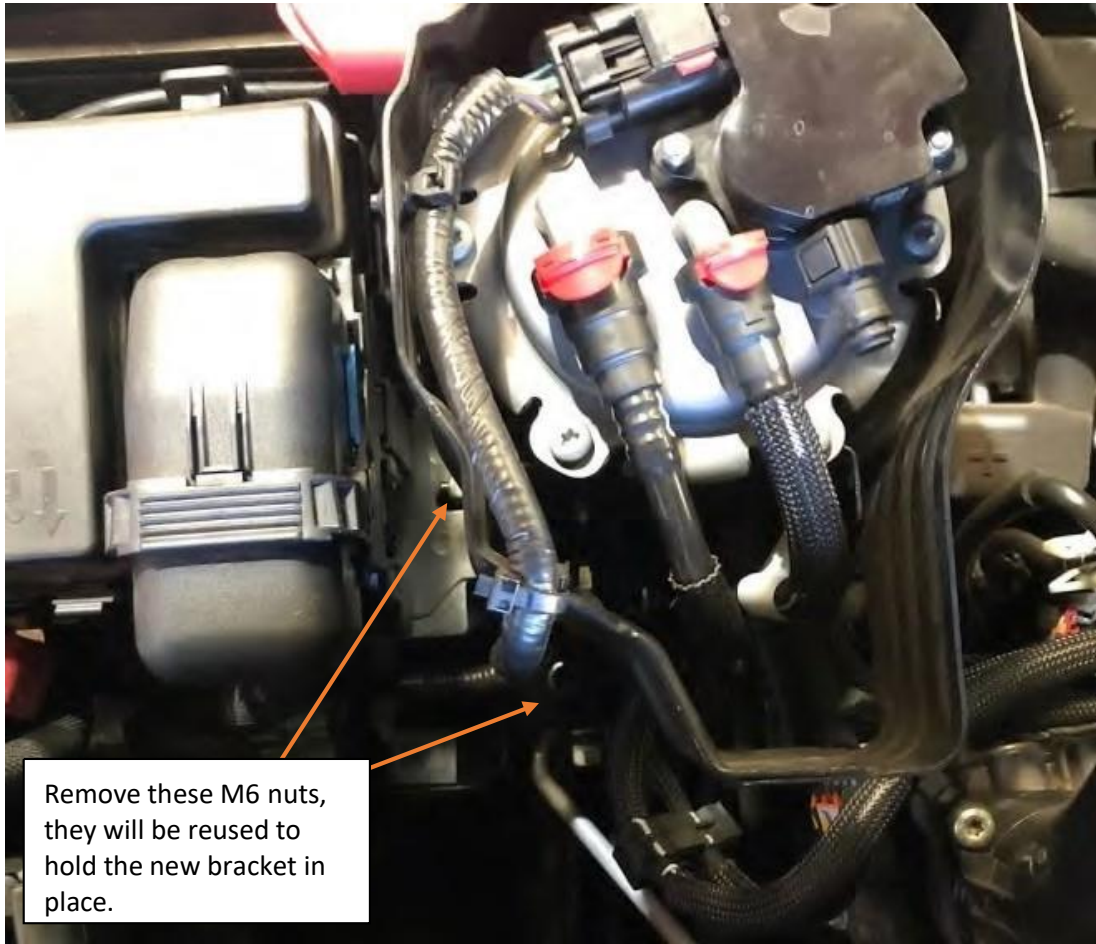

Top down view: image shows new ProVent bracket mounting location

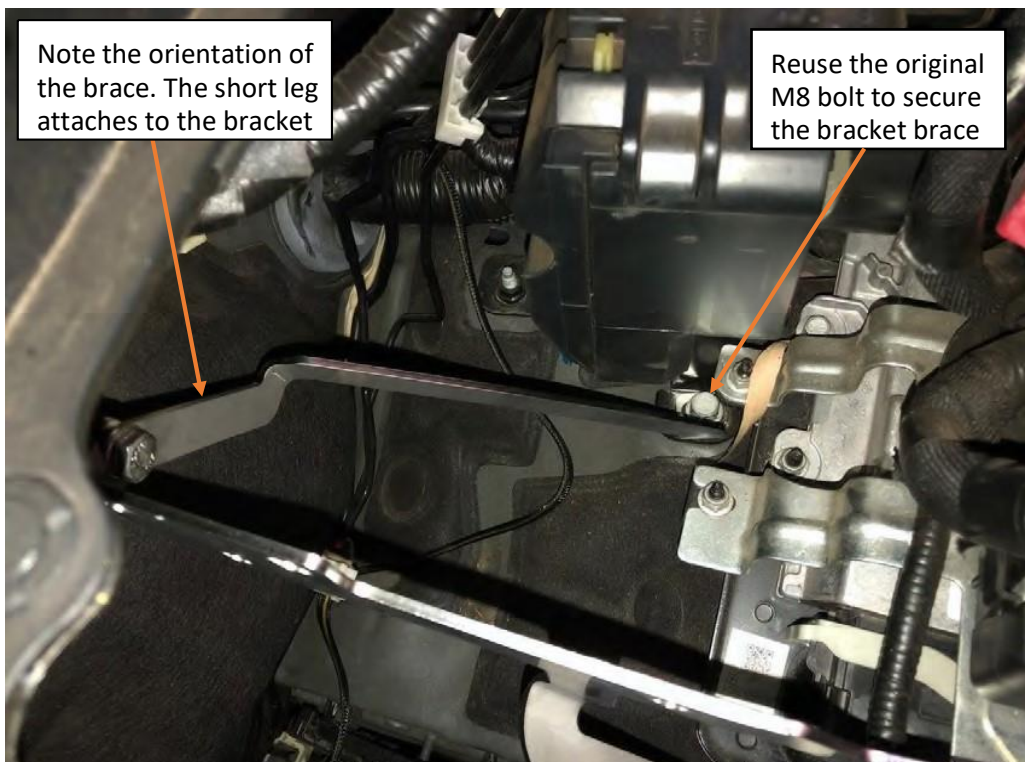
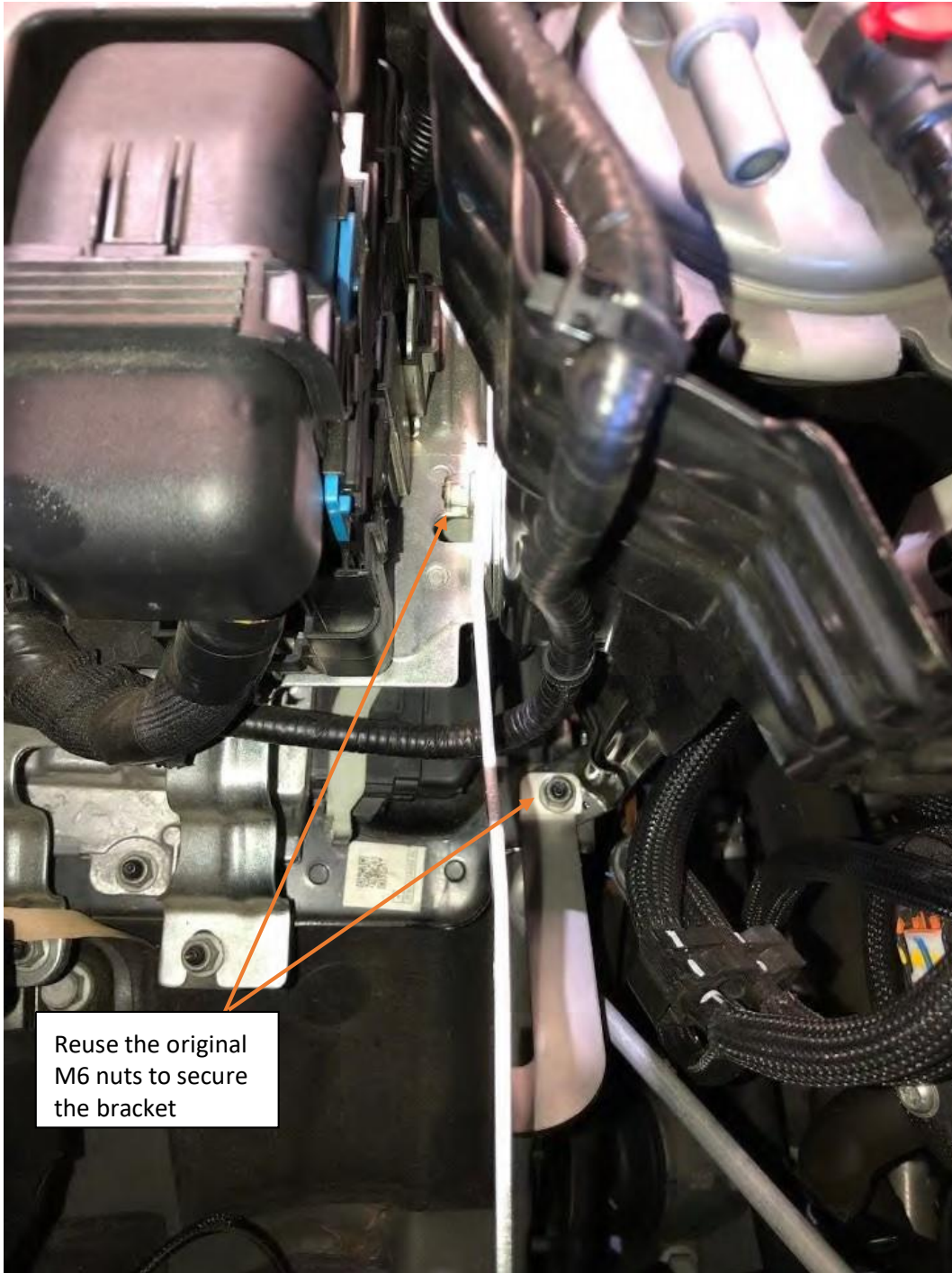

Image shows the rear mounting point and brace orientation

3. Bolt the Brackets into place using the M6 stud from the previous step to locate. Then use the M6 bolt, spring washer and mud washer on the leg to the existing empty threaded hole on the vehicle. Lastly, bolt the brace in place and secure the two brackets together using the M8x16 bolt, two flat washers, a spring washer and M8 nut. The bracket when in place should look like the picture below.



4. If you are installing the PreLine fuel filter system as well as the ProVent, install the bolts for the PreLine from the ABS side towards the engine side, it will make it easier later on.

5. Connect the 12mm (1/2") Hose to the underside of the catch can body, using an 18-20mm Clamp to secure it in place.



ProVent 200 with 12mm hose connected and secured with 18-20mm clamp

6. Feed the 12mm Hose down the side of the engine bay, under the vehicle to an out of the way location, making sure it is clear of any suspension, driveline and exhaust components, fit the Tap hose tail into the hose and secure with an 1820mm clamp.



Hose tail and tap assembly inserted into 12mm hose, secured with 12-20mm worm drive clamp

7. Bolt the ProVent 200 to the bracket using the supplied M8 bolts, spring washers, flat washers and nuts. Make sure to orient the ProVent 200 unit to be facing the same as the picture following.

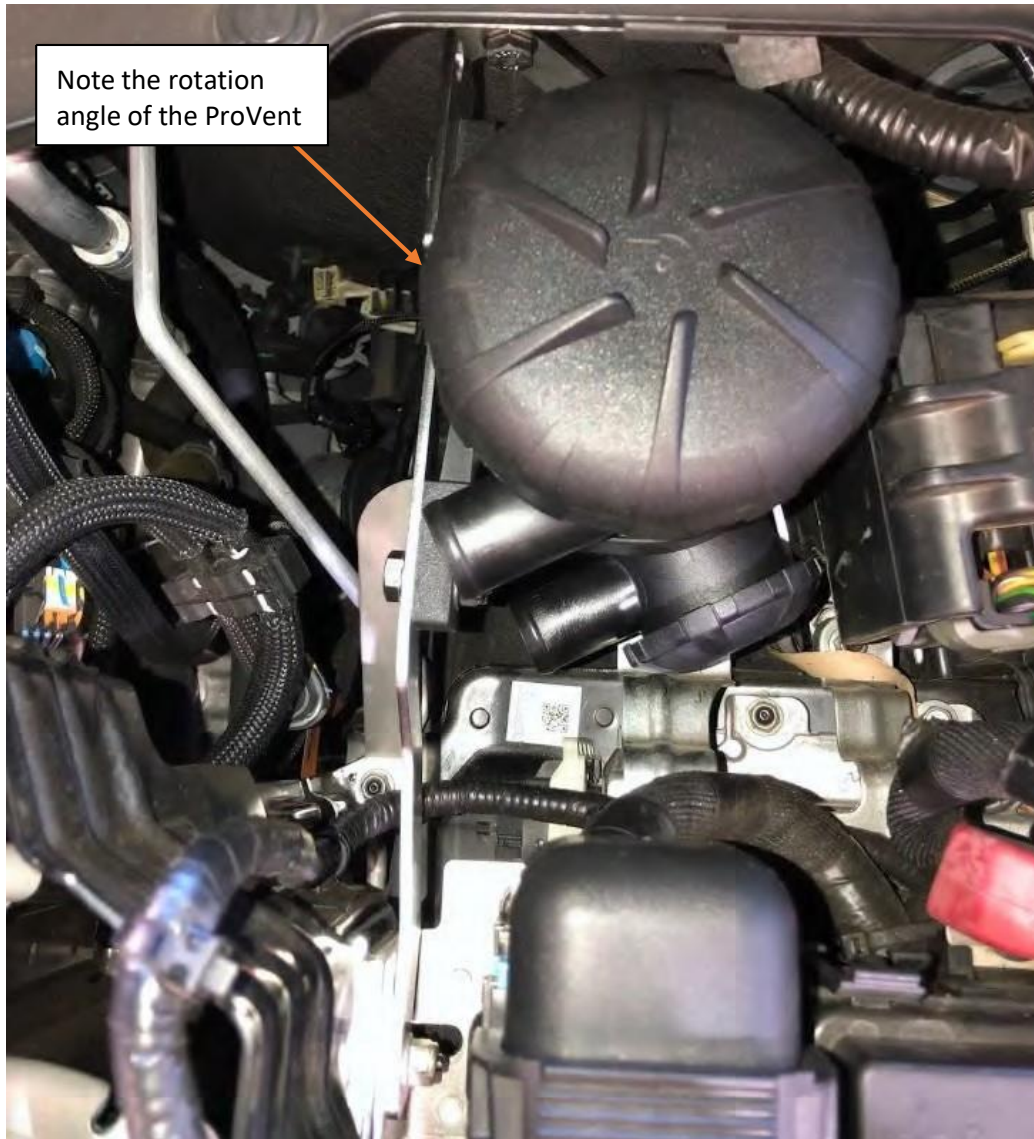

ProVent 200 bolted into place at correct rotation, 25-19mm reducers and elbows are shown installed in this image to give you an idea of fitment (clamps not fitted)

8. Use the supplied cable ties to secure the 12mm hose into the location required under the vehicle to prevent movement. Note: Leave a slight amount of slack in the line where the body and chassis join to prevent stretching the hose.
9. Make sure the tap position is closed and avoid placing the tap in a location in which it will fill with dirt and mud.

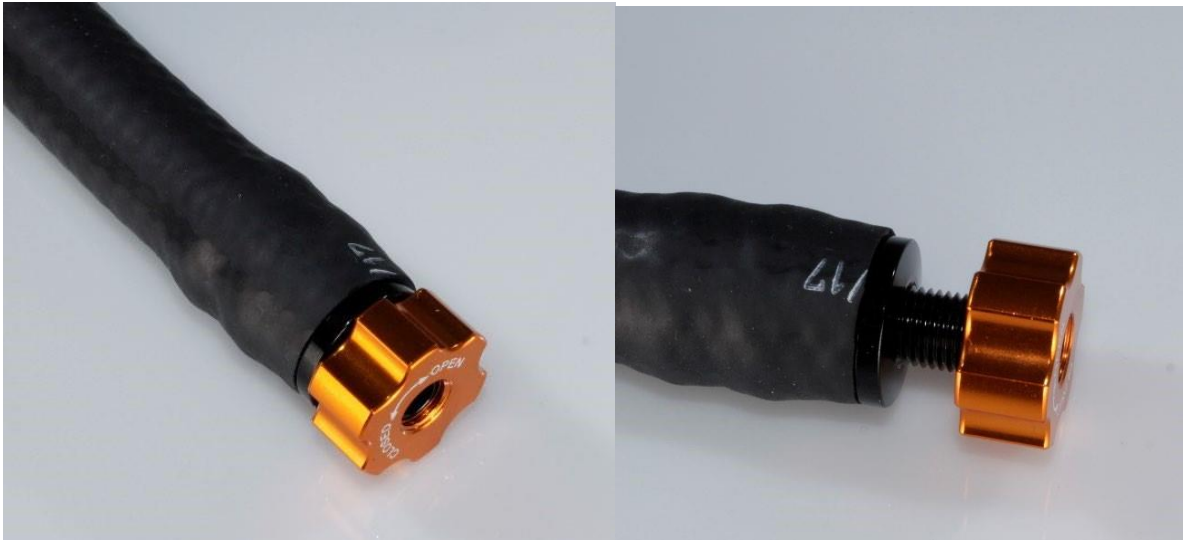

Left image – Tap Open. Right image – Tap Closed.

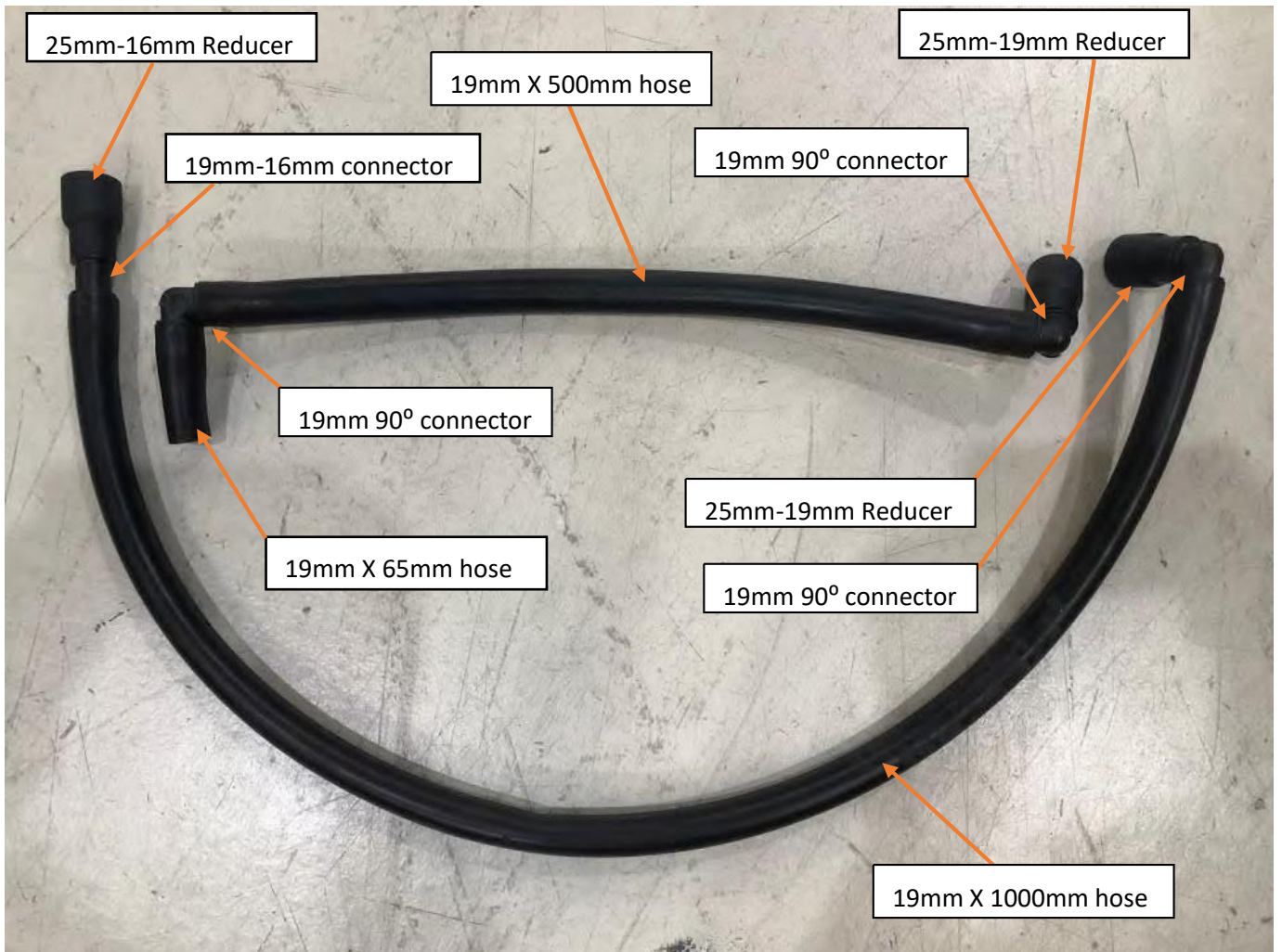

ProVent hose configuration – hose clamps not shown

10. Connect the 25-19mm reducers to the ports on the side of the ProVent 200 unit. Use the 25mm spring clamps to secure in place.
11. To the 19mm end of these reducers, fit the 19mm elbows and use 19mm clamps to secure in place.
12. Mount one end of the first 1000mm long 19mm (3/4") hose to the lower 19mm (3/4") elbow connected to the ProVent 200. Secure with hose clamp.
13. Mount the other end of the same 1000mm long 19mm hose to a 19mm- 16mm straight connector and 25mm-16mm reducer and use clamps to secure. Connect this hose to the engine air intake pipe, where the factory CCV pipe was removed. Secure with hose clamp.
14. Mount one end of the second 500mm 19mm hose to the upper 19mm fitting on the ProVent 200. Secure with hose clamp.
15. Mount the other end of the second 750mm 19mm hose to a 19mm (3/4") 90° joiner fitting and use a clamp to secure. Connect the other side of the 19mm (3/4") 90° joiner fitting to the short 65mm length of hose and use a clamp to secure. Connect this hose to the port on the engine cover where the factory CCV pipe was removed. Secure with hose clamp.



Engine cover connection to ProVent Upper port

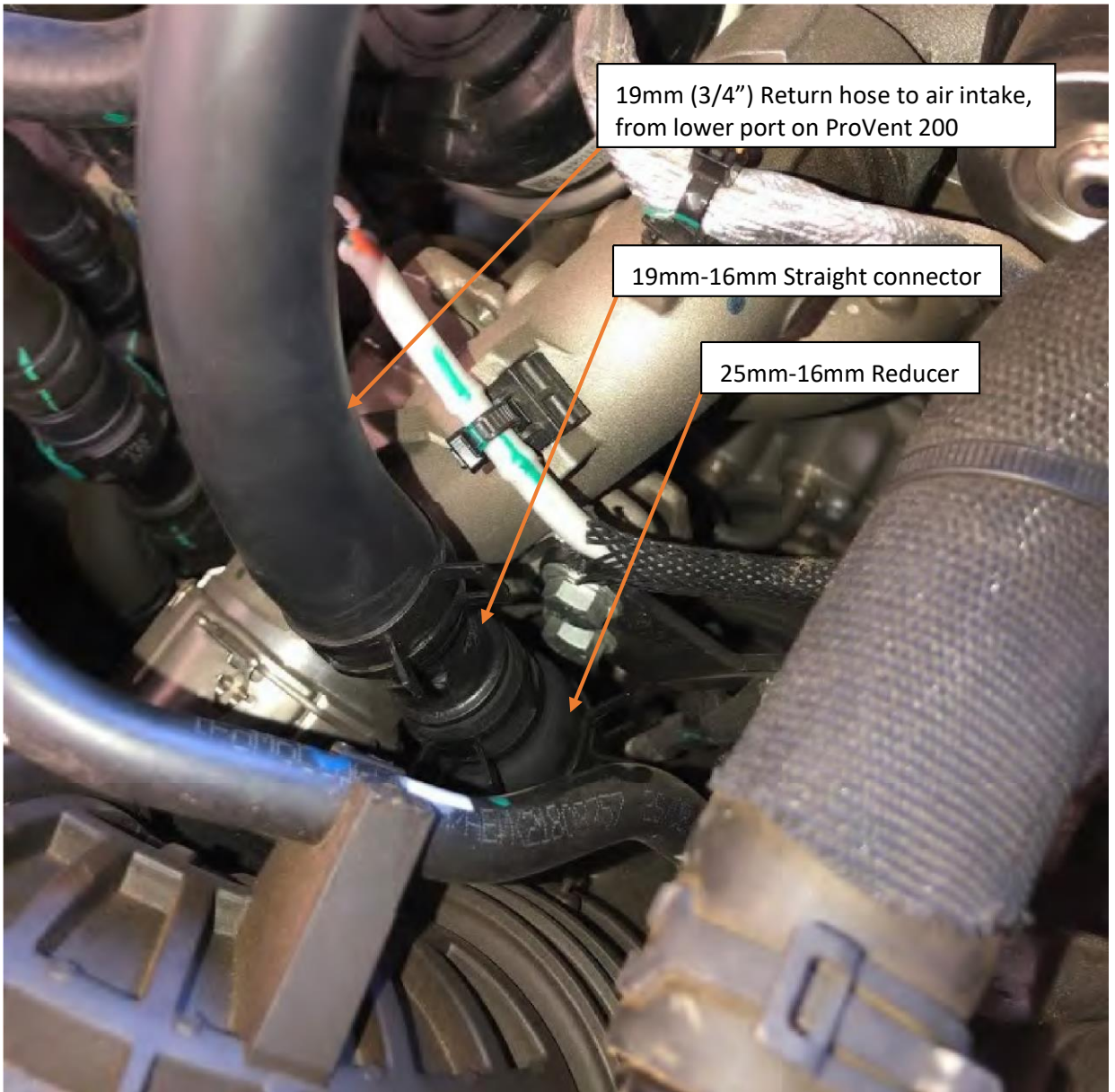

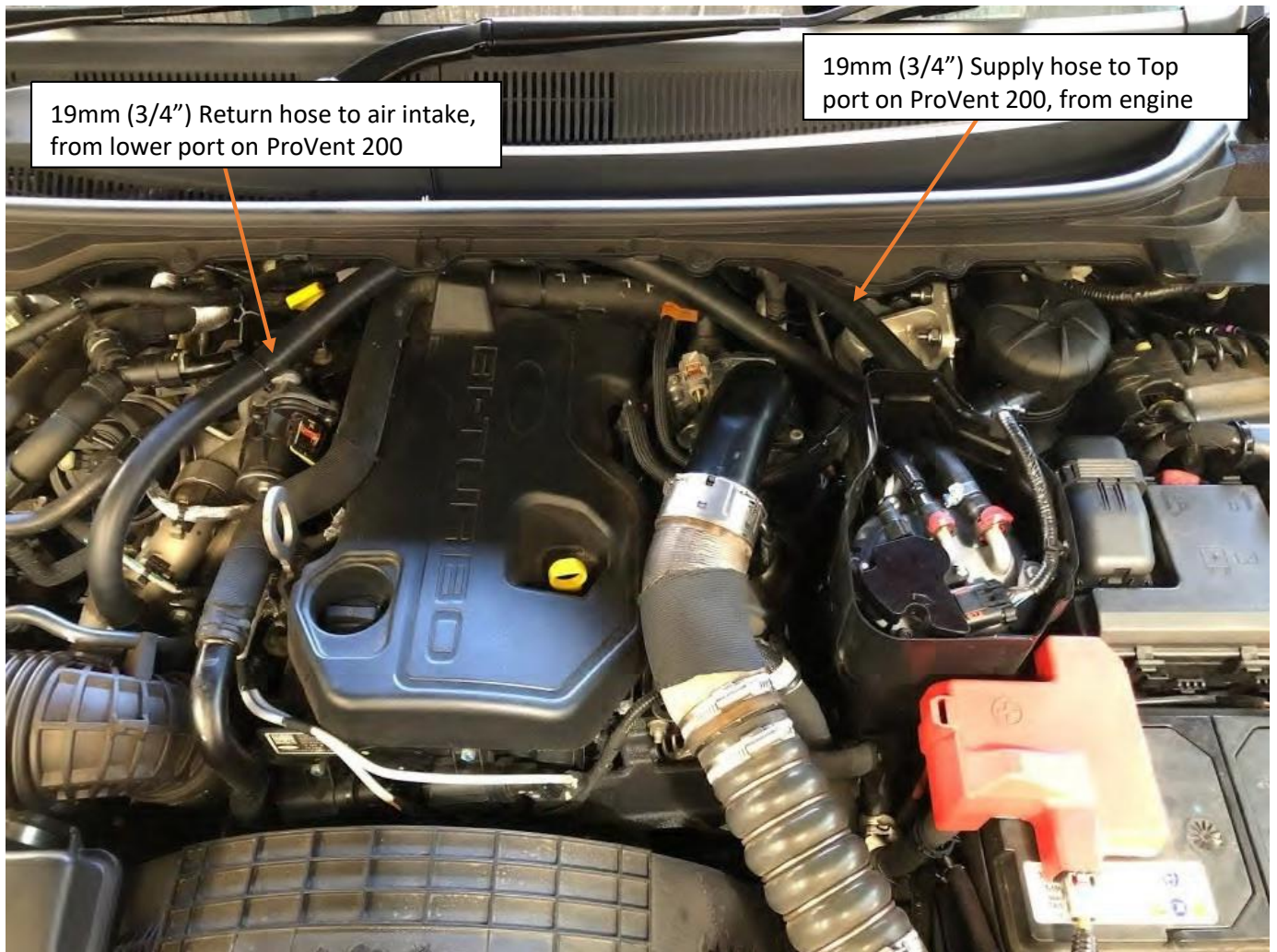

Hose configuration in PX Ranger with ProVent 200 installed. (hose clamps not shown)

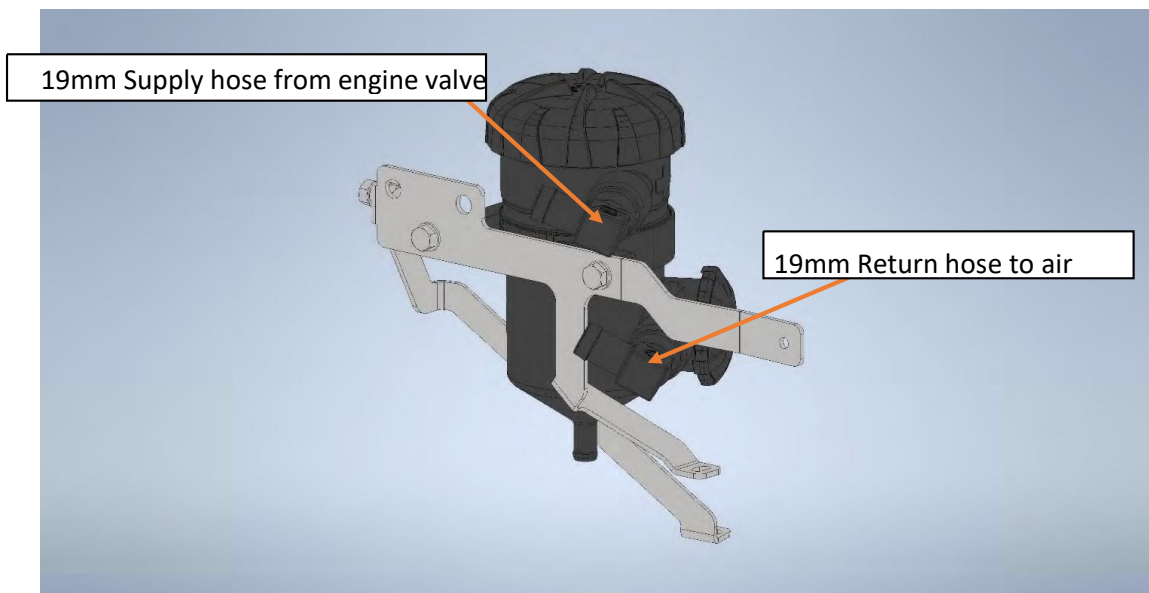

PV200 INTERNAL BYPASS VALVE SECTIONAL DIAGRAM

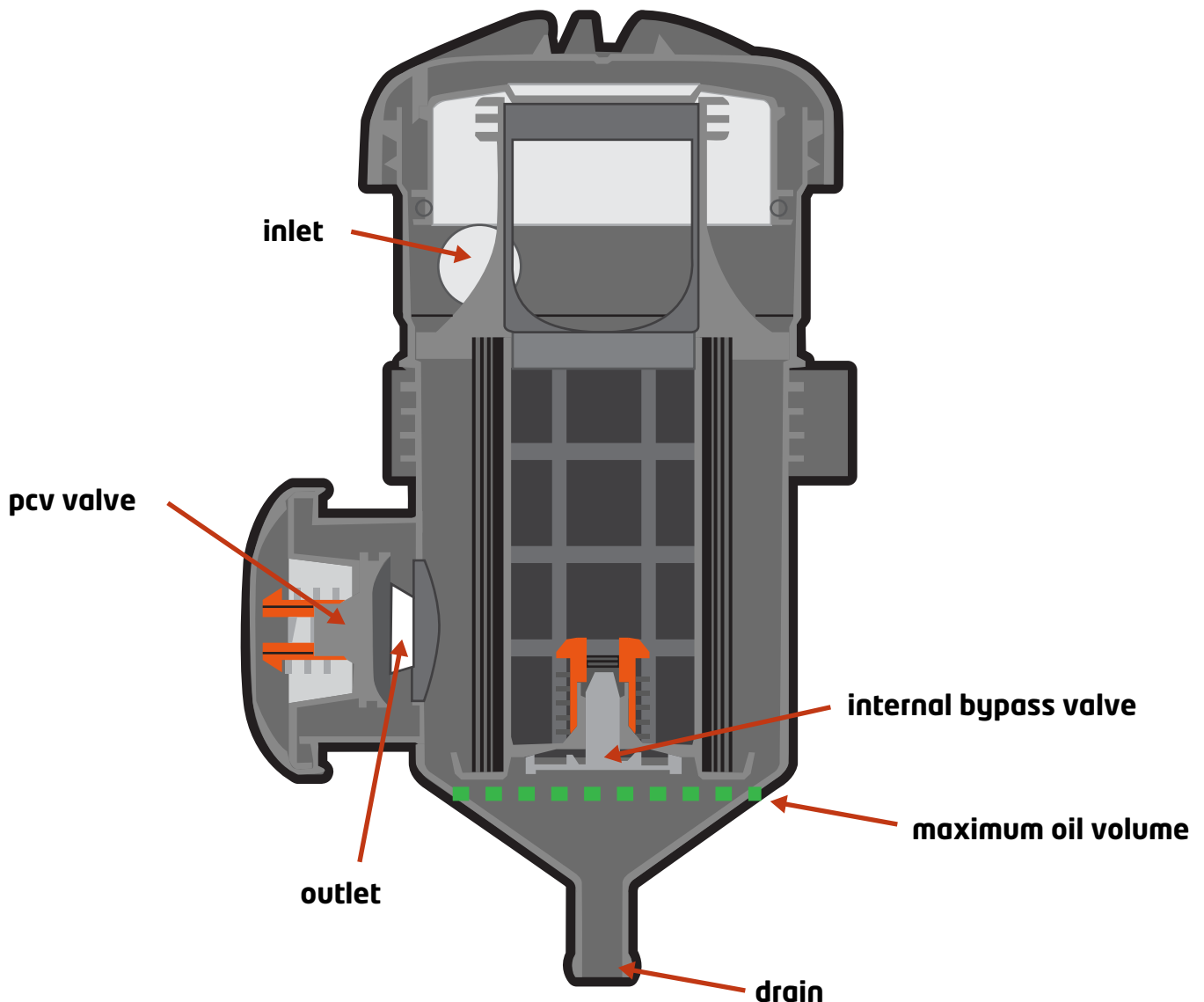

Due to the way the internally vented PV200 works, the PV200 must be drained regularly to ensure correct operation of the internal bypass valve. Failure to regularly draining/servicing the Catch Can may cause engine damage due to over pressurisation of the crankcase ventilation system.

The ■ ■ ■ in the diagram indicates the maximum permissible oil level. For the PV200 internal bypass valve to correctly operate the internal oil volume **MUST NOT** exceed the level indicated by the ■ ■ ■ shown in the diagram.

If the internal oil volume is to exceed the level indicated by the ■ ■ ■ shown in the diagram, the internal bypass valve cannot operate as designed due to it being submerged. This condition is likely to cause over pressurisation of the crankcase ventilation system and damaging the engine.

WARNING: Colder climates can cause increased condensation inside the Catch Can. This will fill the reservoir quicker than oil and will need to be drained regularly. Failure to do so could & can damaged the Catch Can or vehicle.

ProVent 200

The housing can (prior to installation) be turned in the holder in 30° steps around the longitudinal axis.

This enables the position "Inlet and outlet fitting to flange" to be flexibly adjusted to the installation situation.

- Remove the retaining clip (1) upward from the groove and turn the holder into the desired position.
- Press the holder together somewhat in the desired position and engage the retaining clip in the groove again
- Mount the holder in the vertical position. Recommended tightening torque for M8 screws: 10 Nm.
- Ensure sufficient strength of the screw and nut material.
- Connect the hoses to the inlet, outlet and oil return fittings (make sure a sufficient length of hose is pushed on) and secure with hose clamps (see Chap.4.2 and 4.3).
- Connect the oil return hose (and non-return valve if necessary) to the oil sump.
- To ensure proper functioning, the ProVent should be protected against dirt (mount splash guards if necessary).

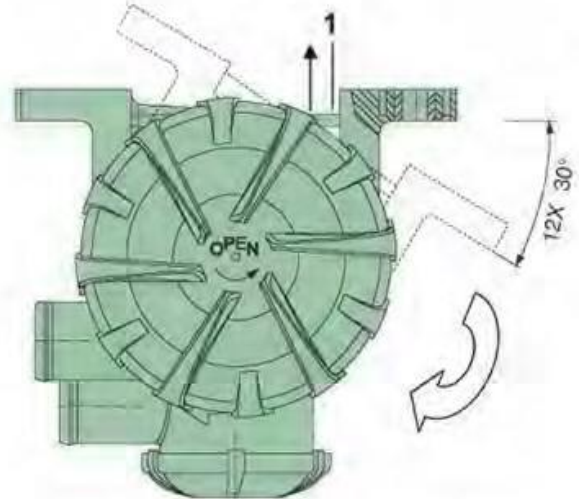

Fig. 5 Positions of outlet for ProVent 200



Fig. 6 Holder for ProVent 200

End of ProVent Ultimate Catch Can installation

Go to Next Page for Fuel Manager Pre-filter Installation Guide

Fuel Manager Pre-Filter Installation Guide

This document is to be used as a guide for the installation of the **Direction-Plus™ Fuel Manager Pre-filter kit to a Ford Everest YNWS (2018-2022) and Ranger PXIII Bi-Turbo YNWS (2019-2022)**.

It is recommended that the installation of the product be carried out by a competent qualified mechanic.

Important before starting

- Ensure the engine bay is clean and free from contaminants.
- The filter head has direction arrows indicating the direction of flow.
- You have the correct tools to complete the fitment.
- Read the instructions in full and familiarize yourself with the installation before commencing any work.

Included in the kit

- 1 x Mounting Bracket A
- 1 x Mounting Bracket B
- 8 x Cable Ties
- 1 x M8x16 Bolt
- 2 x M8 Flat Washers
- 1 x M8 Stainless Steel Nut
- 1 x Fuel Manager FM100
- 2 x 10mm straight push lock hose fittings
- 2 x M16 x 1.5 adapters
- 2 x M16 flat washers
- 1 x fuel hose 10mm
- 2 x 10mm hose clamps
- 2 x M10 bolt
- 2 x M10 nut
- 4 x M10 washers

Approximate mounting location

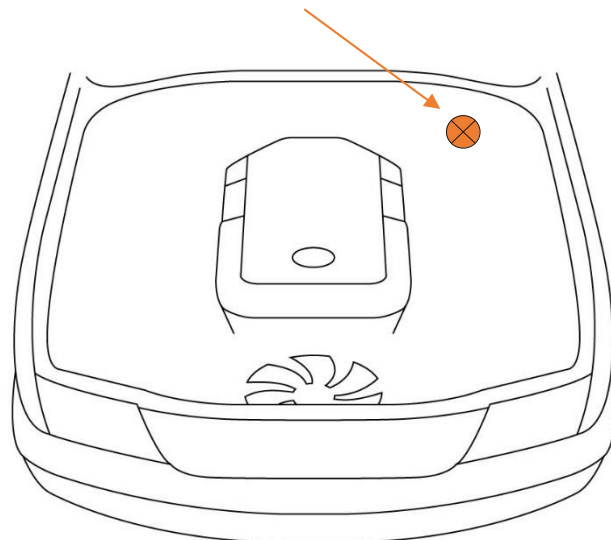

Kit contents are subject to change based on availability.

Fuel Manager Pre-Filter Installation Guide

Fuel Manager Pre-Filter Normal Flow Header Connection

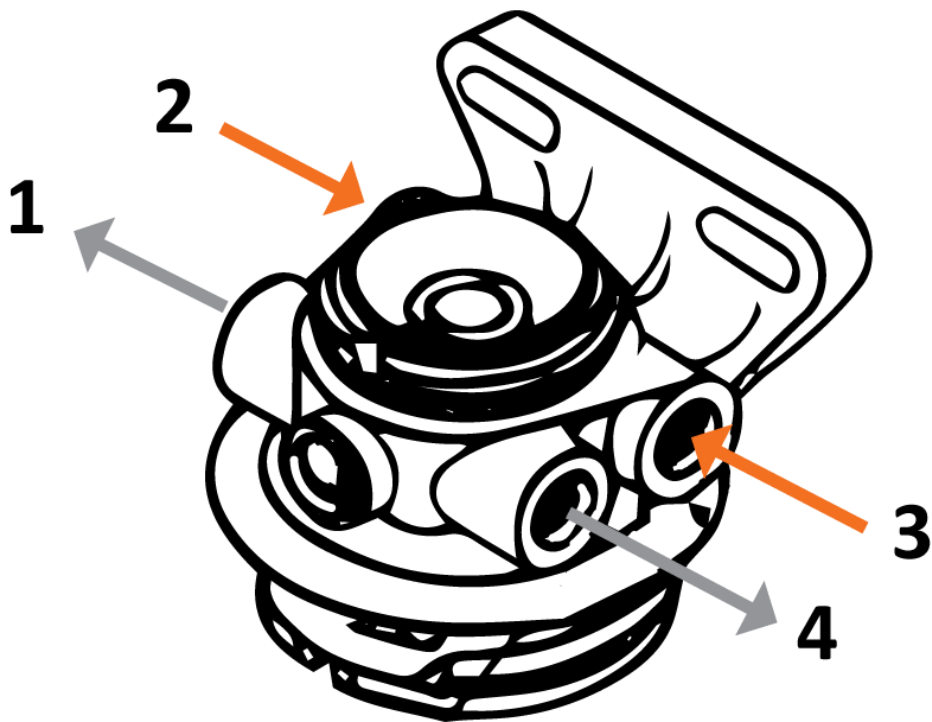

Ports 2 and 3 = INLET
Ports 1 and 4 = OUTLET

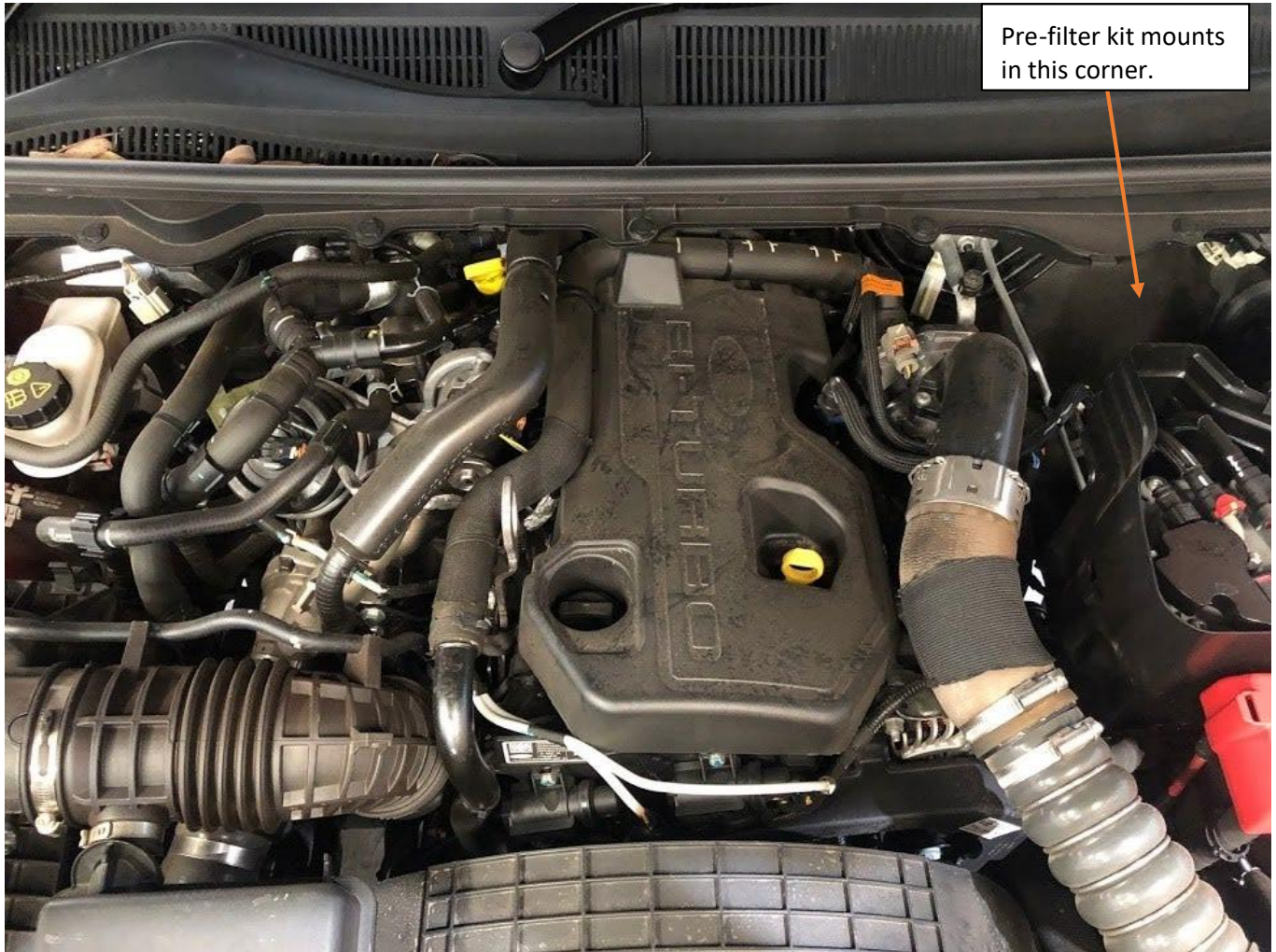

Ranger PXIII Engine Bay – Overall View

1. Locate the 2x M6 nuts located on the factory fuel filter bracket. They will need to be removed to allow fitment of the new bracket. You will also need to remove the bolt that retains the ABS unit nearby, the brace secures to this and the factory bolt gets reused.

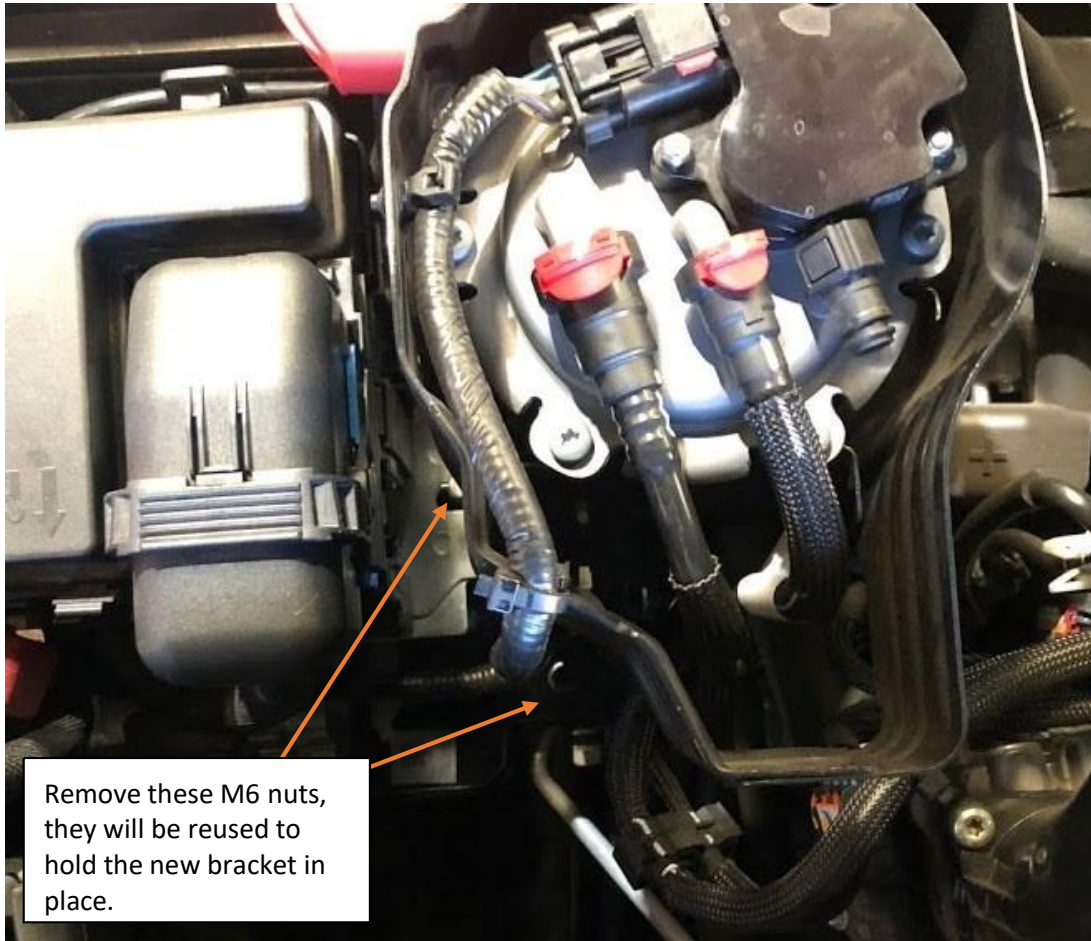

Top down view: image shows bracket mounting location

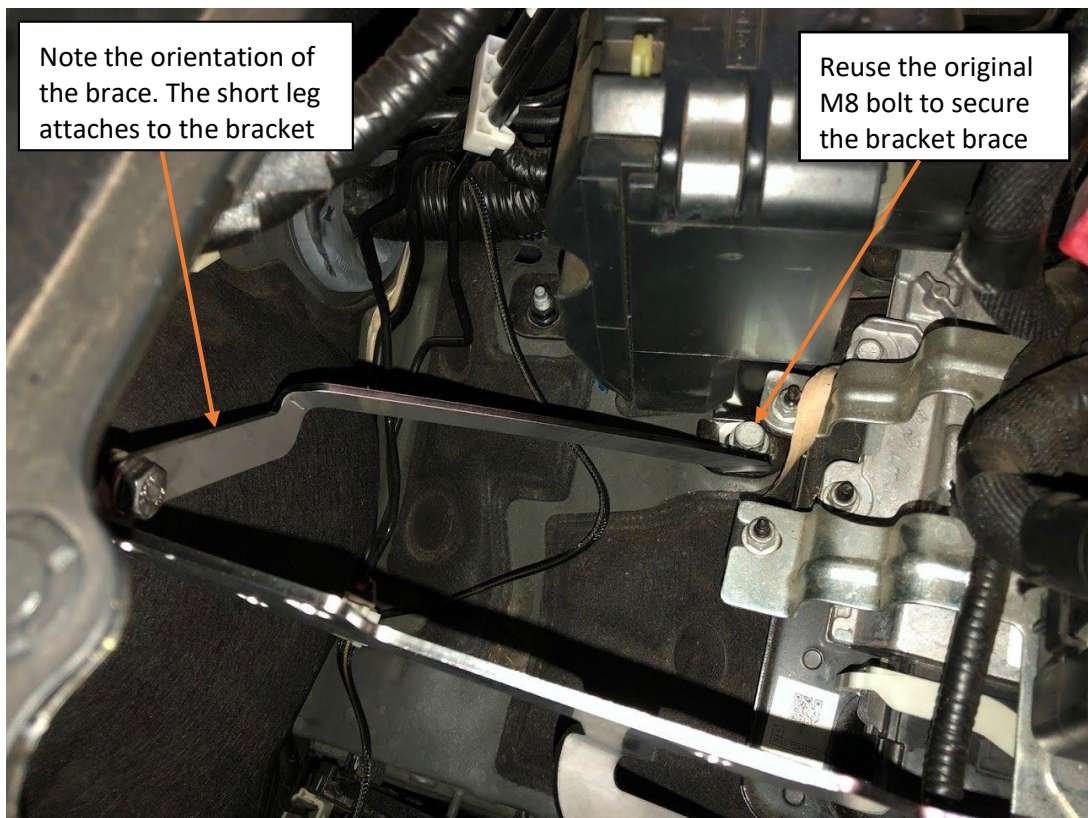
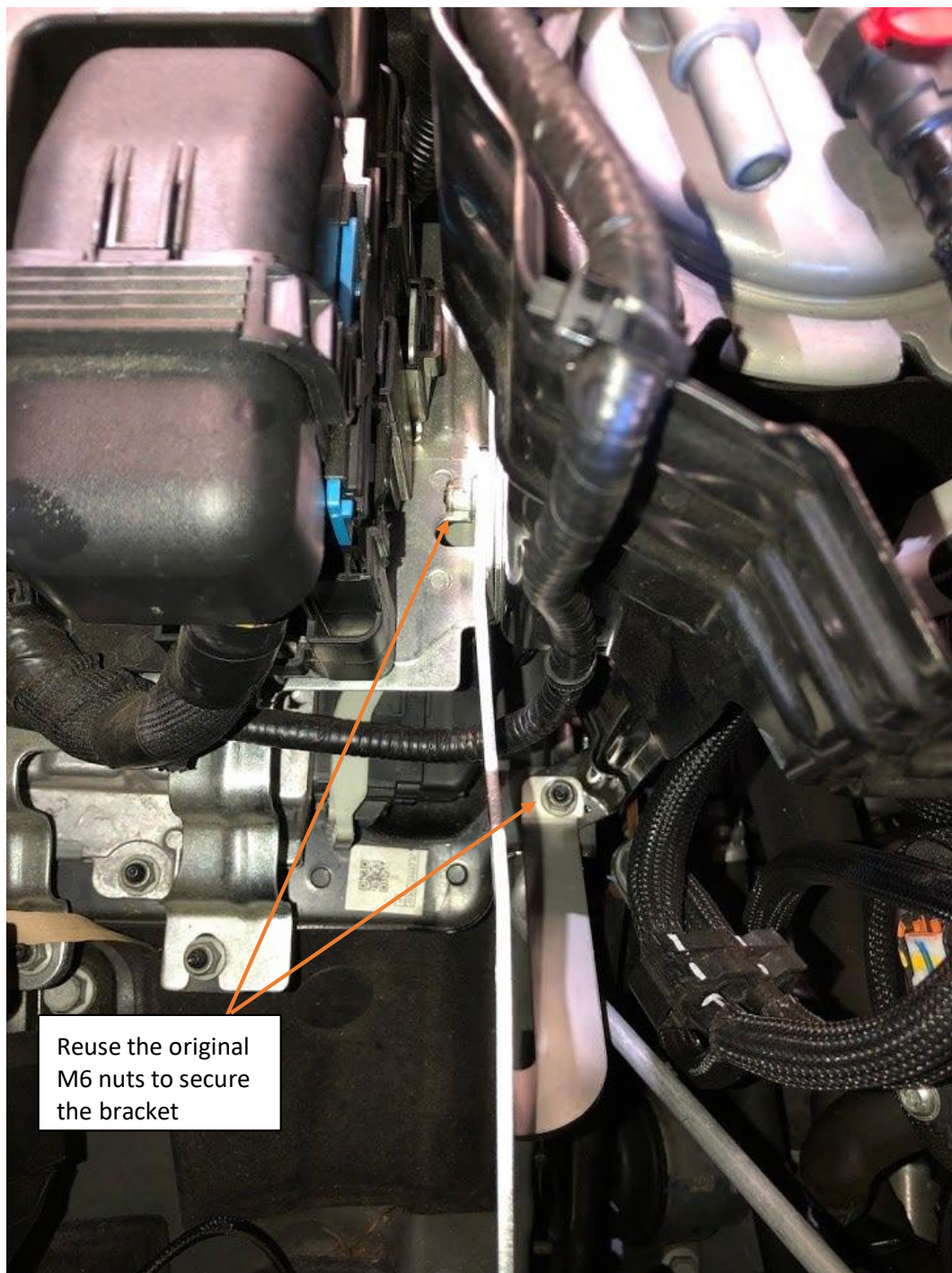

Image shows the rear mounting point and brace orientation

2. Bolt the Brackets into place using the M6 stud from the previous step to locate. Then use the M6 bolt, spring washer and mud washer on the leg to the existing empty threaded hole on the vehicle. Lastly, bolt the brace in place and secure the two brackets together using the M8x16 bolt, two flat washers, a spring washer and M8 nut. The bracket when in place should look like the picture below.



3. Install the M16x1.5 adapters and M16 flat washers to the inlet and outlet ports that are facing toward the front of the vehicle when the pre-filter is installed.

Note: depending on installation you may need to remove and reposition the already installed plugs

4. Mount the Fuel Manager Pre-filter assembly to the mounting bracket using the 2 x 10mm x 30mm bolts, 2 x 10mm flat washers.



5. Remove the RED quick disconnect fitting from the original filter head (the larger fitting) and the other end from the pipe coming from the tank. You will require a sharp knife to cut along the length of the nylon hose to remove it from the pipe. Remove the factory piece of pipe.

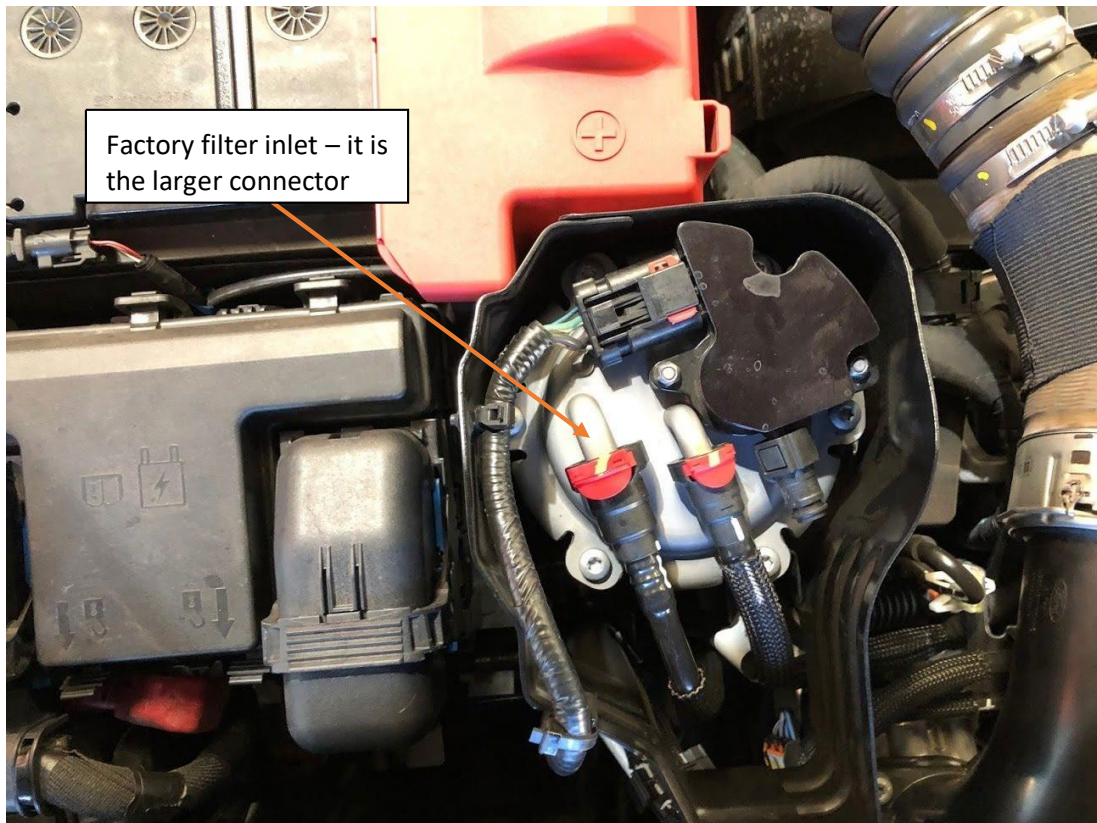

6. Using a knife remove the quick disconnect fitting from the nylon pipe by cutting along the length on the hose.

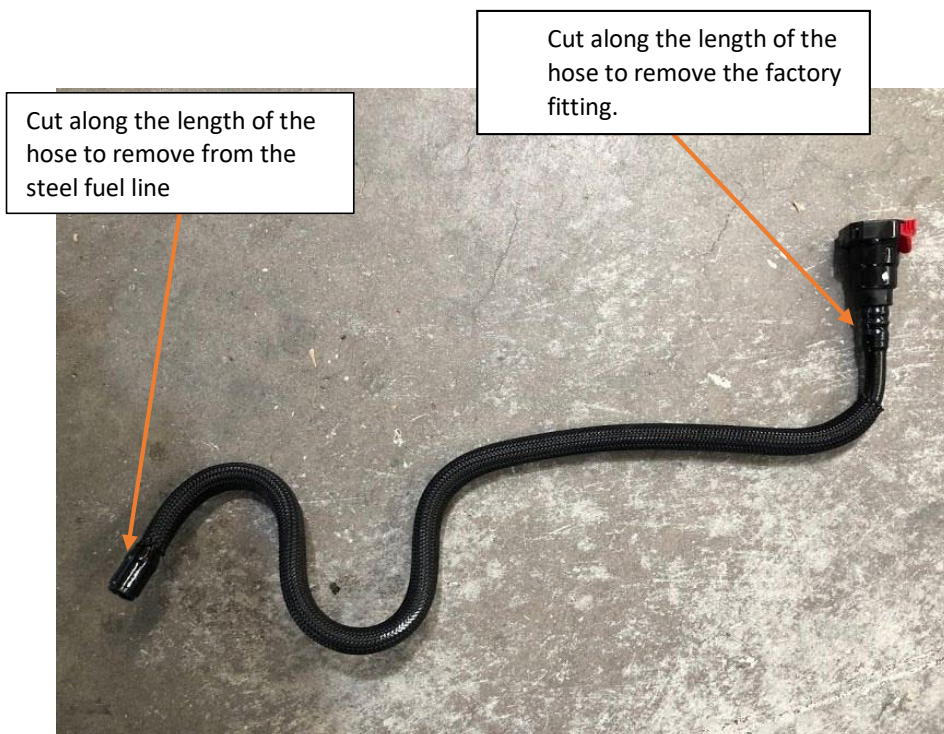

7. With one end of the supplied 10mm fuel hose, Lubricate the inside portion of one end using diesel fuel or WD40
8. Install one of the 10mm straight push-lock fittings into the pre-lubricated end of the 10mm fuel hose, ensuring that the hose stops firmly against the inside of the bell cover.
9. Connect the 10mm straight push-lock fitting to the inlet of the pre-filter housing. Adjust the angle of the fitting tail to clear any obstructions.
10. Route the 10mm fuel hose down to the steel fuel pipe that was connected to inlet of the factory fuel filter and cut the hose to length approximately 25mm past the end of the steel fuel pipe.
11. Connect the hose coming from the inlet of the pre-filter to the steel line and secure with a hose clamp.
12. With the remaining length of 10mm fuel hose Lubricate the inside portion of one end using diesel fuel or WD40.
13. Install the last 10mm push-lock fitting into the pre-lubricated end of the 10mm fuel hose, ensuring that the hose stops firmly against the inside of the bell cover.
14. Run the fuel hose up the factory fuel filter inlet and trim to length.
15. Connect the other end of the hose coming from the pre-filter outlet to the quick disconnect fitting removed from the factory nylon fuel hose and secure with a clamp

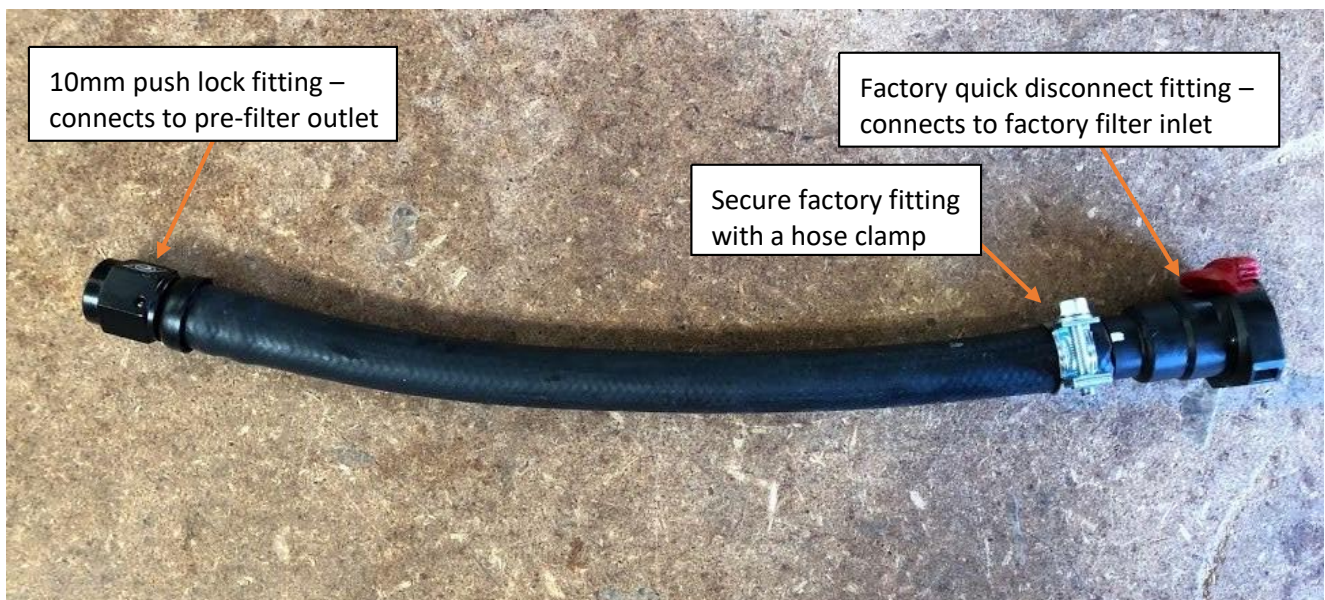

hose construction from pre-filter outlet to factory filter inlet

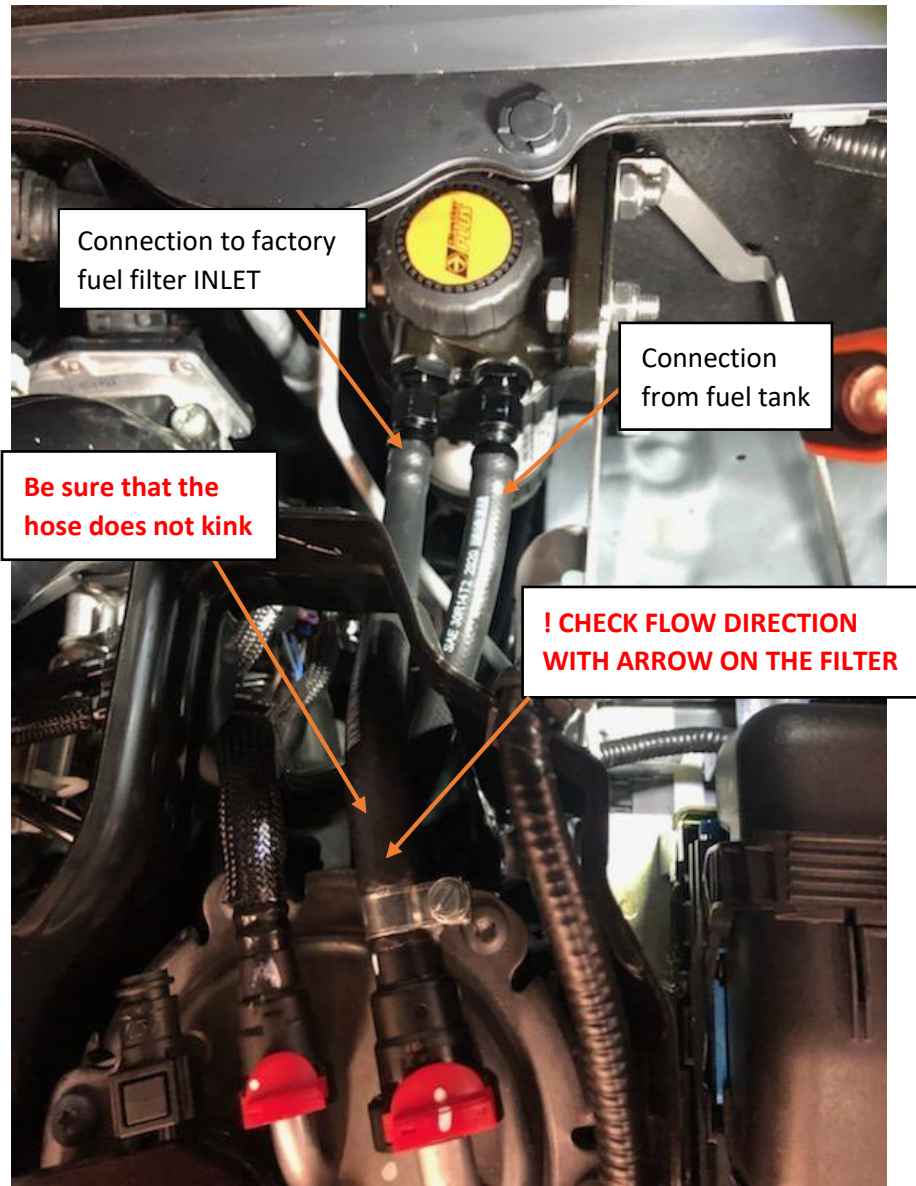

16. Route the 10mm fuel hose to the inlet of the factory fuel filter and cut the hose to length, approximately 25mm past the end of the inlet barb
17. Install the last 9.89mm female quick disconnect fitting in the end of the same fuel hose and secure with a hose clamp. Connect this hose to the inlet of the factory fuel filter and secure with a supplied hose clamp.
18. Using the supplied nylon cable ties carefully secure both fuel hoses, ensuring they are not kinked and cannot contact any hot components.
19. Remove any loose tools from the work area
20. Prime fuel system by turning the ignition key ON and allow the system to prime for approximately 30-60 seconds, repeat 4-6 times. You should hear the fuel pump running then switch off every time you turn the ignition on.
21. Start and run the vehicle checking for leaks – if the vehicle stalls repeat step 20



Completed installation of the Fuel Manager PRE-FILTER FM664DPK

End of Installation Guide