



Toyota Land Cruiser 70 Series Direction-Plus™ Fuel Manager Pre-Filter + ProVent Ultimate Catch Can Kit Installation Guide

This document is to be used as a guide for the installation of the **Direction-Plus™ ProVent® Ultimate Catch Can + Fuel Manager pre-filter kit to a 2007+ Toyota Land Cruiser 70 Series V8 Diesel**. It is recommended that the installation of the product be carried out by a competent qualified mechanic.

Important Before Starting

- Ensure you have the correct tools to complete the fitment
- Read the instructions in full and familiarize yourself with the installation, before commencing any work

Maintenance / servicing

- It is recommended to drain the FM100 element every 5,000 – 10,000km
- FM100 element is to be replaced every 40,000km or as per your vehicles service interval
- It is recommended to drain the ProVent® every 5,000
- ProVent® element is to be replaced every 40,000km

Included in the kit

- 1 x Mann + Hummel ProVent® 200
- 1 x Mounting Bracket
- 1 x 850mm of 16mm Hose
- 1 x 750mm of 16mm Hose
- 2 x 60mm of 16mm Hose
- 4 x 16mm 90°Joiners
- 8 x 16mm Hose Clamps
- 2 x 25mm Hose Clamps
- 2 x 16mm to 25mm Hose Coupler
- 8 x Cable Ties
- 2 x M8x25 Bolts
- 1 x M8x16 Bolt
- 5 x M8 Flat Washers
- 3 x M8 Spring Washers
- 2 x M8 Nuts
- 1000mm of 12mm Hose ProVent® Drain
- 1x Drain Tap assembly 1 x
- 12mm Hose Clamp
- 1x FM100 assembly
- 2x M10 Bolts
- 4x M10 Washers
- 2x M10 Nyloc Nuts
- 2x M6x16 Bolts
- 4x M6 Flat Washers
- 2x M6 Nyloc Nuts
- 2x ¼" NPT Adapter
- 1x Thread sealant
- 2x 12mm Straight Push Lock Hose Fitting
- 1x 3m Length of 12mm Fuel Hose
- 2x 1.5m Length of 35mm Heat Sleeve
- 2x 12mm Fuel Hose Clamps
- 2x ¼" Plug

Approximate mounting location

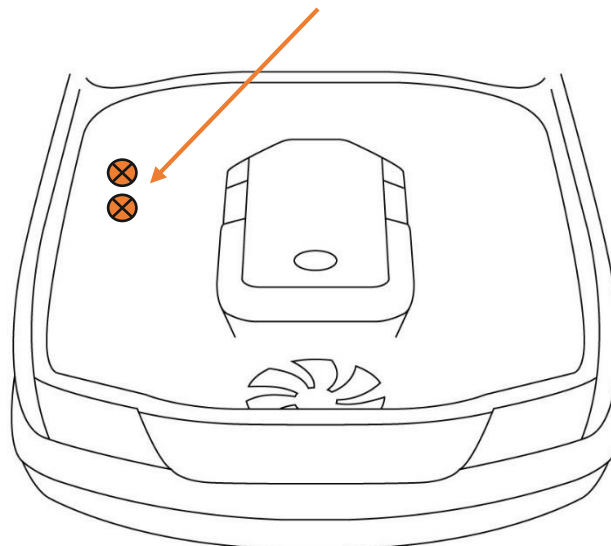

*Kit contents are subject to change based on component availability and/or refinement

ProVent Ultimate Catch Can - Installation Guide

1. Begin by locating the factory bypass hose which runs from the black box in the front of the intercooler on the passenger side of the vehicle to the intake pipe just under the top radiator hose in front of it, the hose is only about 200mm in length and shaped like an "L". Once located, this hose needs to be removed. Retain the spring clamps for reuse.



Land Cruiser 70 series engine bay

2. Connect each of the 60mm long 16mm hoses to the ports the factory bypass hose was just removed from. Use a light coat of rubber care or WD-40 to help get them on. Secure in place with the factory spring clamps.
3. Insert a 16mm 90° joiner fitting into each of the hoses, using a 16mm spring clamp to secure them in place.
4. Connect the 12mm Hose to the underside of the catch can and use a 12mm spring clamp to secure it in place.



Provent® 200 with 12mm hose connected and secured with 12mm spring clamp

5. On the ABS control unit, remove the nut closest to the engine and the nut closest to the rear of the vehicle. Install the bracket on top of the ABS control unit mounting bracket, loosely securing reusing the original nuts. Next, bolt the ProVent® 200 to the bracket using the supplied bolts and washers.
6. Using 1x M8x16 bolt and 2x M6x16 bolts and nuts, loosely install the upper reinforcing brace.
7. Adjust bracket as required and tighten all nuts and bolts securing the bracket

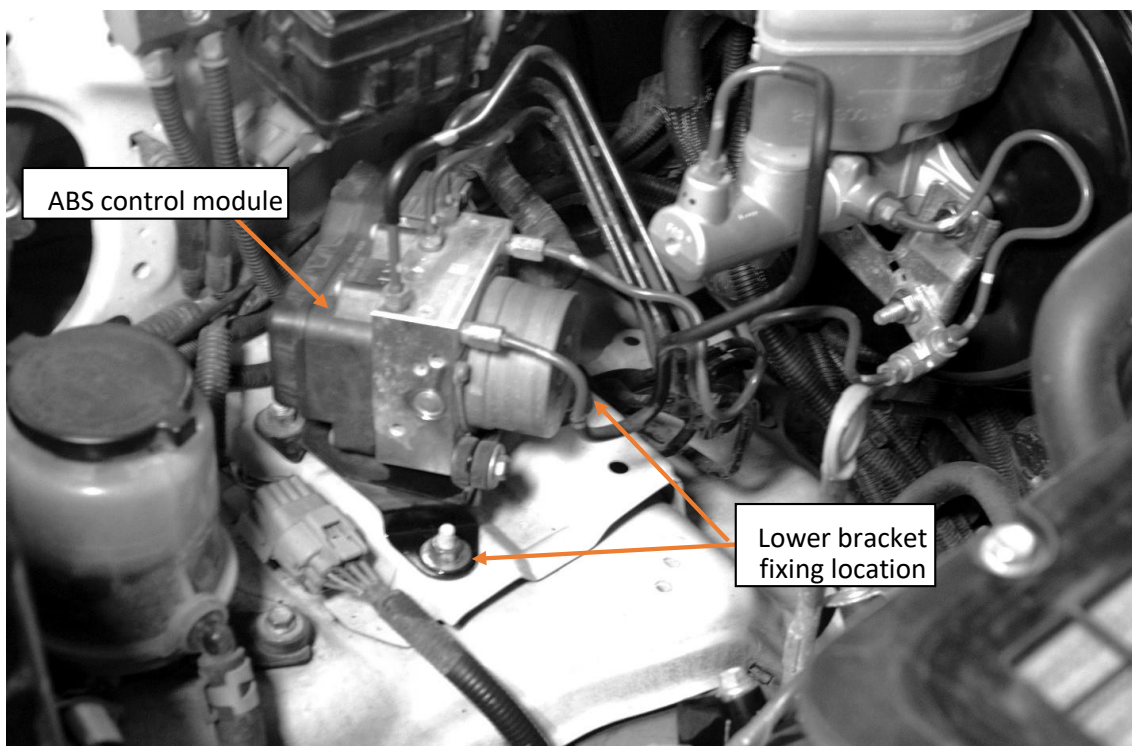

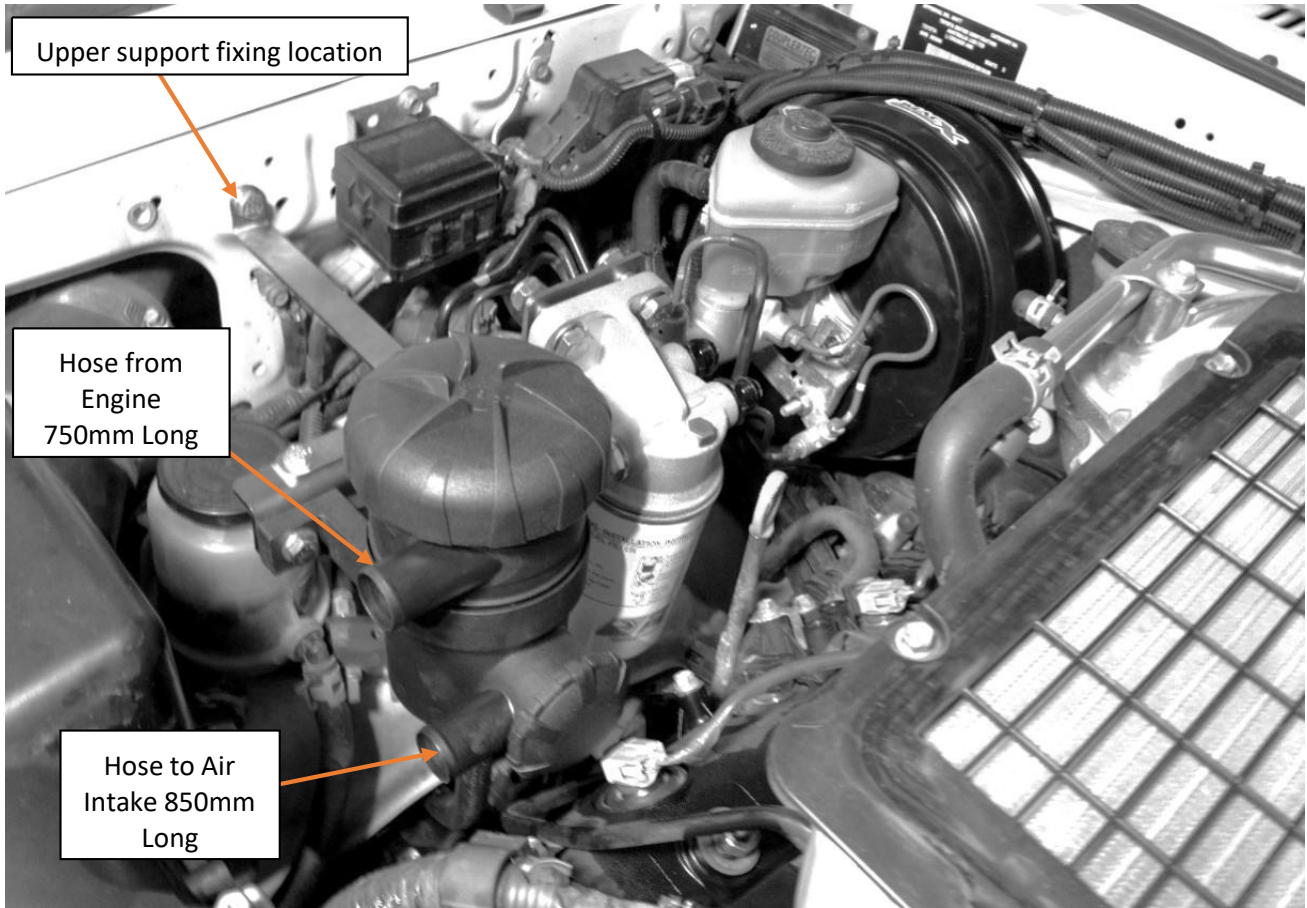

Pre-assembled ProVent® 200 with Land Cruiser 70 series dual bracket

8. Feed the 12mm Hose down under the vehicle to an out of the way location, making sure it is clear of any suspension, driveline and exhaust components, fit the Tap hose tail into the hose.
9. Install the ProVent® as pictured above



Hose tail and tap assembly inserted into 12mm hose, hose clamp not required

10. Use the supplied cable ties to secure the 12mm hose into the location required to prevent movement, just leave a slight amount of slack in the line where the body and chassis join to prevent stretching the hose.
11. Make sure the tap position is closed and avoid placing the tap in a location in which it will fill with dirt and mud.



Left image – Tap Open.

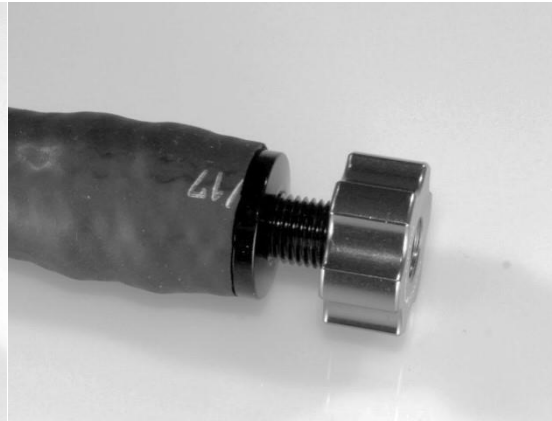

Right image – Tap Closed.

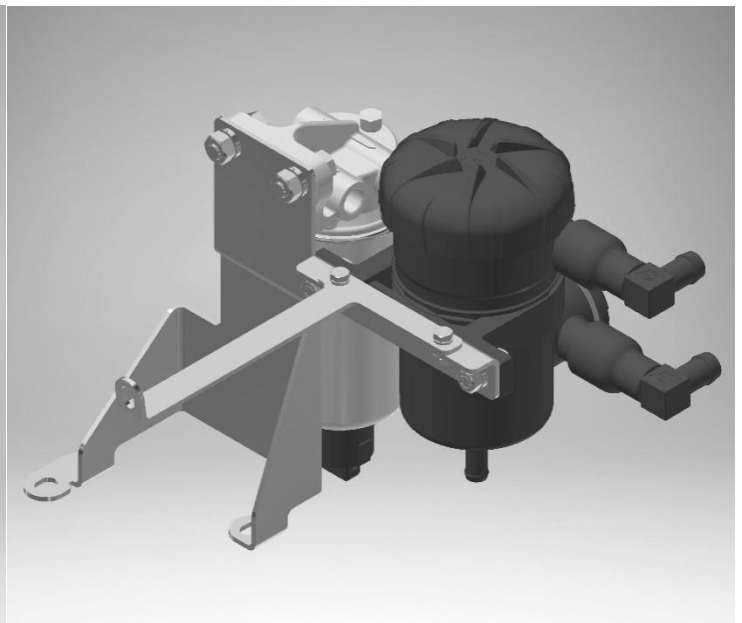
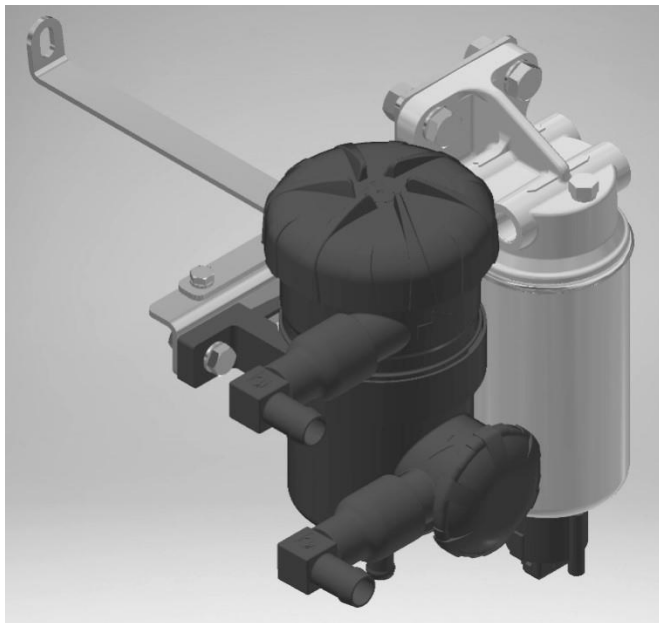

ProVent 200 Assembled onto LC70 Dual Bracket

12. Mount one end of the 850mm long 16mm hose to the lower 16mm 90° joiner fitting on the ProVent® 200. Use a 16mm spring clamp to secure it in place.
13. Mount the other end of the 850mm long 16mm hose to the 16mm 90° joiner fitting on the hose connected to the hose running to the black air intake pipe on the front passenger side, using a 16mm spring clamp to secure it in place.
14. Mount one end of the 750mm 16mm hose to the Upper 16mm 90° joiner fitting on the ProVent® 200. Use a 16mm spring clamp to secure it in place.
15. Mount the other end of the 750mm 16mm hose to the 16mm 90° joiner fitting on the hose connected to the hose running to the black box in front of the intercooler on the front passenger side, using a 16mm spring clamp to secure it in place.

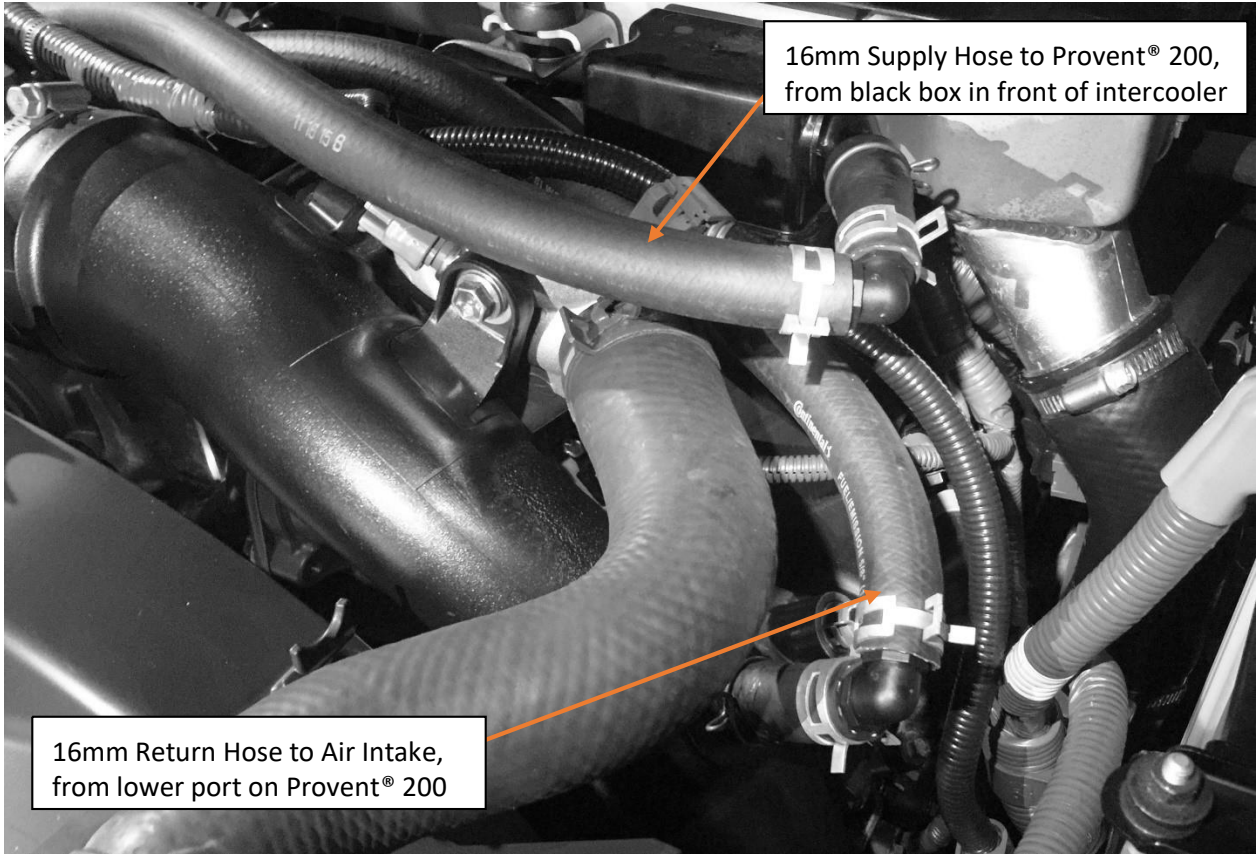

Engine bay hose locations for Land Cruiser 70 series V8 diesel

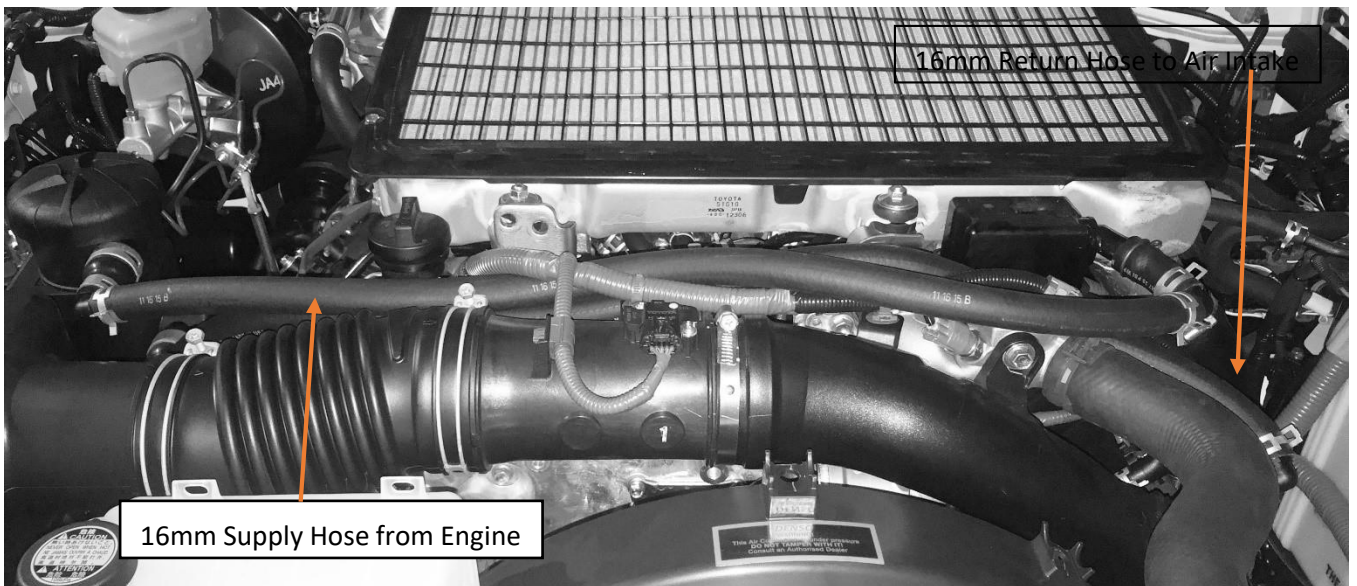

End of ProVent Installation Guide

PV200 INTERNAL BYPASS VALVE SECTIONAL DIAGRAM

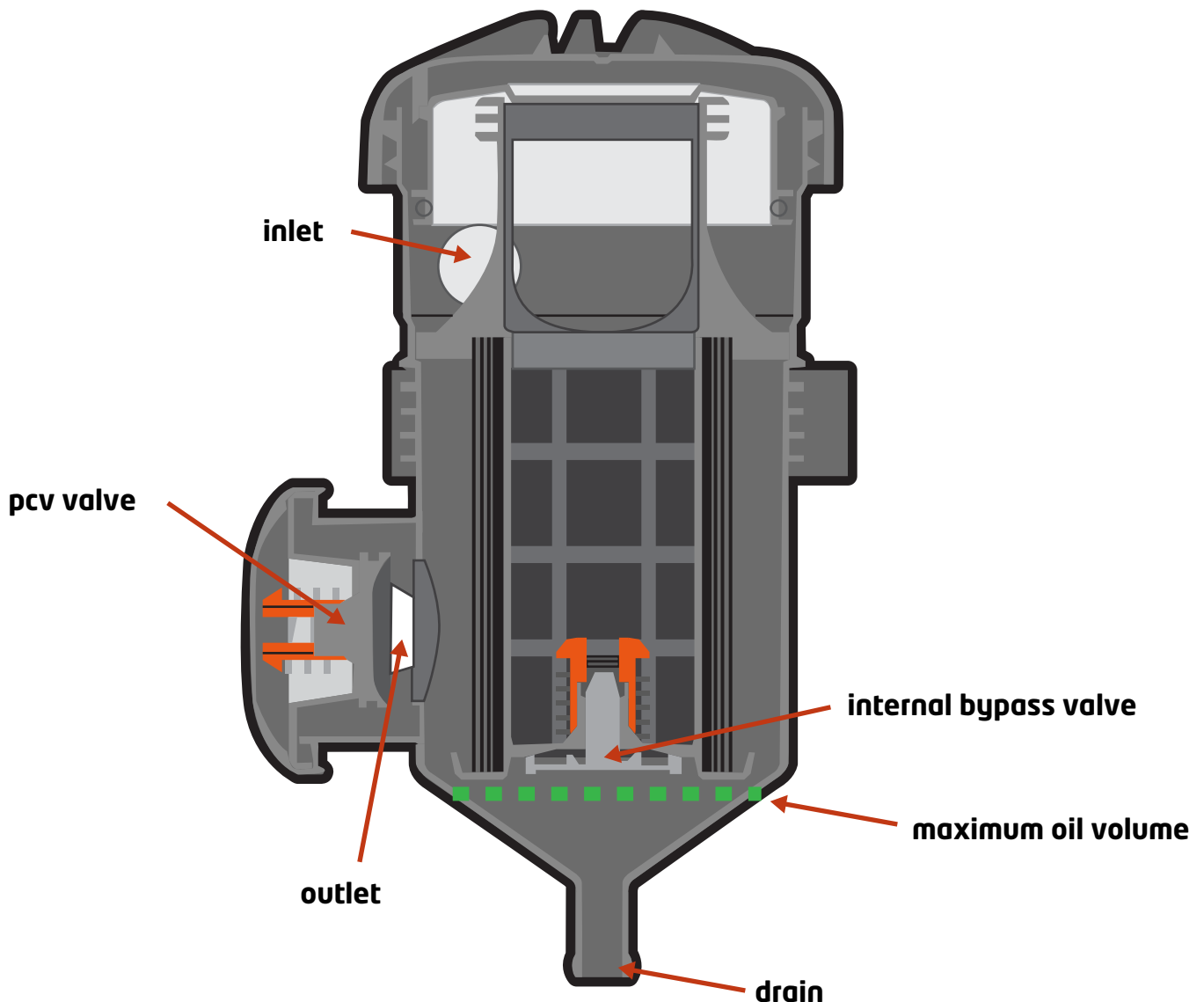

Due to the way the internally vented PV200 works, the PV200 must be drained regularly to ensure correct operation of the internal bypass valve. Failure to regularly draining/servicing the Catch Can may cause engine damage due to over pressurisation of the crankcase ventilation system.

The ■ ■ ■ in the diagram indicates the maximum permissible oil level. For the PV200 internal bypass valve to correctly operate the internal oil volume **MUST NOT** exceed the level indicated by the ■ ■ ■ shown in the diagram.

If the internal oil volume is to exceed the level indicated by the ■ ■ ■ shown in the diagram, the internal bypass valve cannot operate as designed due to it being submerged. This condition is likely to cause over pressurisation of the crankcase ventilation system and damaging the engine.

WARNING: Colder climates can cause increased condensation inside the Catch Can. This will fill the reservoir quicker than oil and will need to be drained regularly. Failure to do so could & can damaged the Catch Can or vehicle.

ProVent 200

The housing can (prior to installation) be turned in the holder in 30° steps around the longitudinal axis.

This enables the position "Inlet and outlet fitting to flange" to be flexibly adjusted to the installation situation.

- Remove the retaining clip (1) upward from the groove and turn the holder into the desired position.
- Press the holder together somewhat in the desired position and engage the retaining clip in the groove again
- Mount the holder in the vertical position. Recommended tightening torque for M8 screws: 10 Nm.
- Ensure sufficient strength of the screw and nut material.
- Connect the hoses to the inlet, outlet and oil return fittings (make sure a sufficient length of hose is pushed on) and secure with hose clamps (see Chap.4.2 and 4.3).
- Connect the oil return hose (and non-return valve if necessary) to the oil sump.
- To ensure proper functioning, the ProVent should be protected against dirt (mount splash guards if necessary).

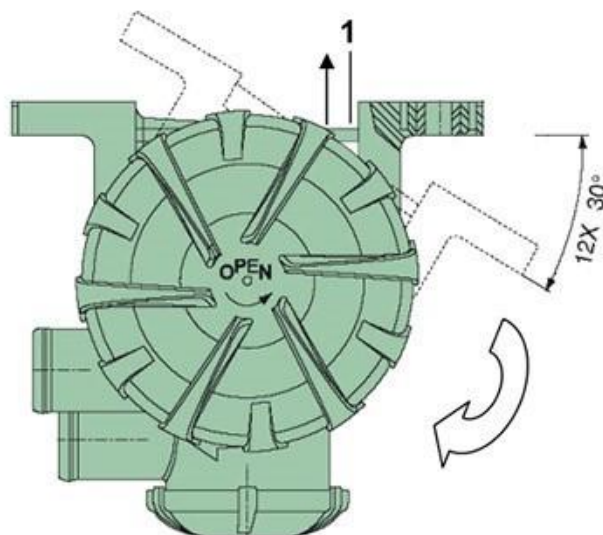

Fig. 5 Positions of outlet for ProVent 200

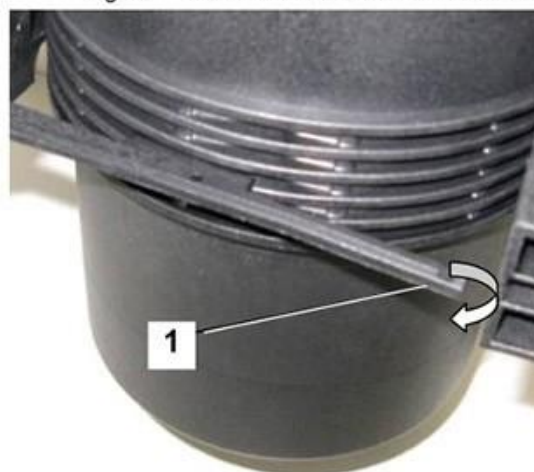

Fig. 6 Holder for ProVent 200

End of ProVent Ultimate Catch Can installation

Go to Next Page for Fuel Manager Pre-filter Installation Guide

Fuel Manager pre-filter Installation Guide

Fuel Manager Pre-Filter Normal Flow Header Connection

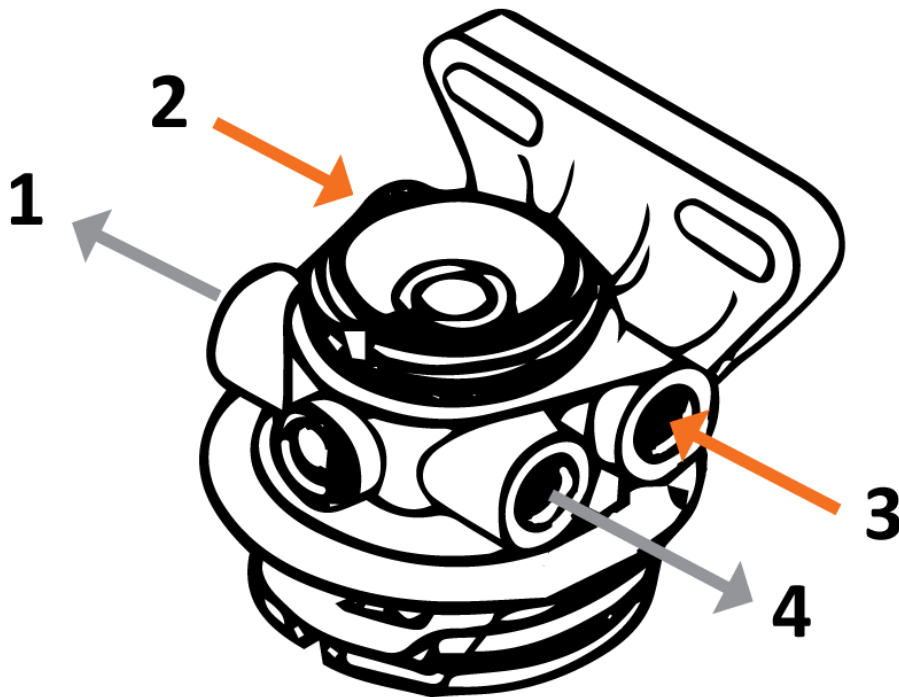

Ports 2 and 3 = INLET
Ports 1 and 4 = OUTLET

1. Using the supplied 10mm bolts, washers and nuts, mount the FM100 pre-filter assembly filter to rear mounting location of the bracket
2. Using a small amount of thread sealant Install the two ¼" NPT straight adapters to the filter head, so that when the filter is mounted on the bracket, they will both be facing toward the rear of the vehicle
3. Using a small amount of thread sealant install the two-blanking plug into the remaining ports

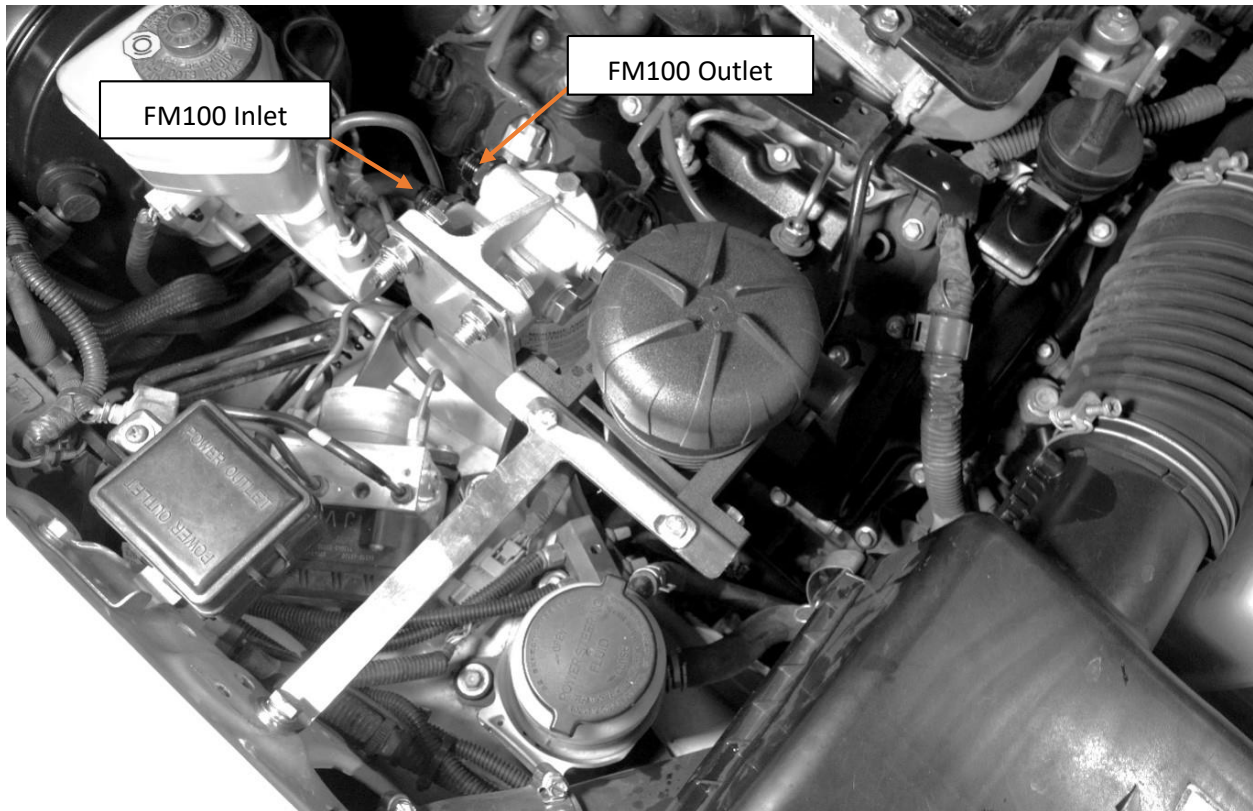

4. Remove the factory fuel filter supply hose. Retain this hose if you wish to remove the kit at any point.

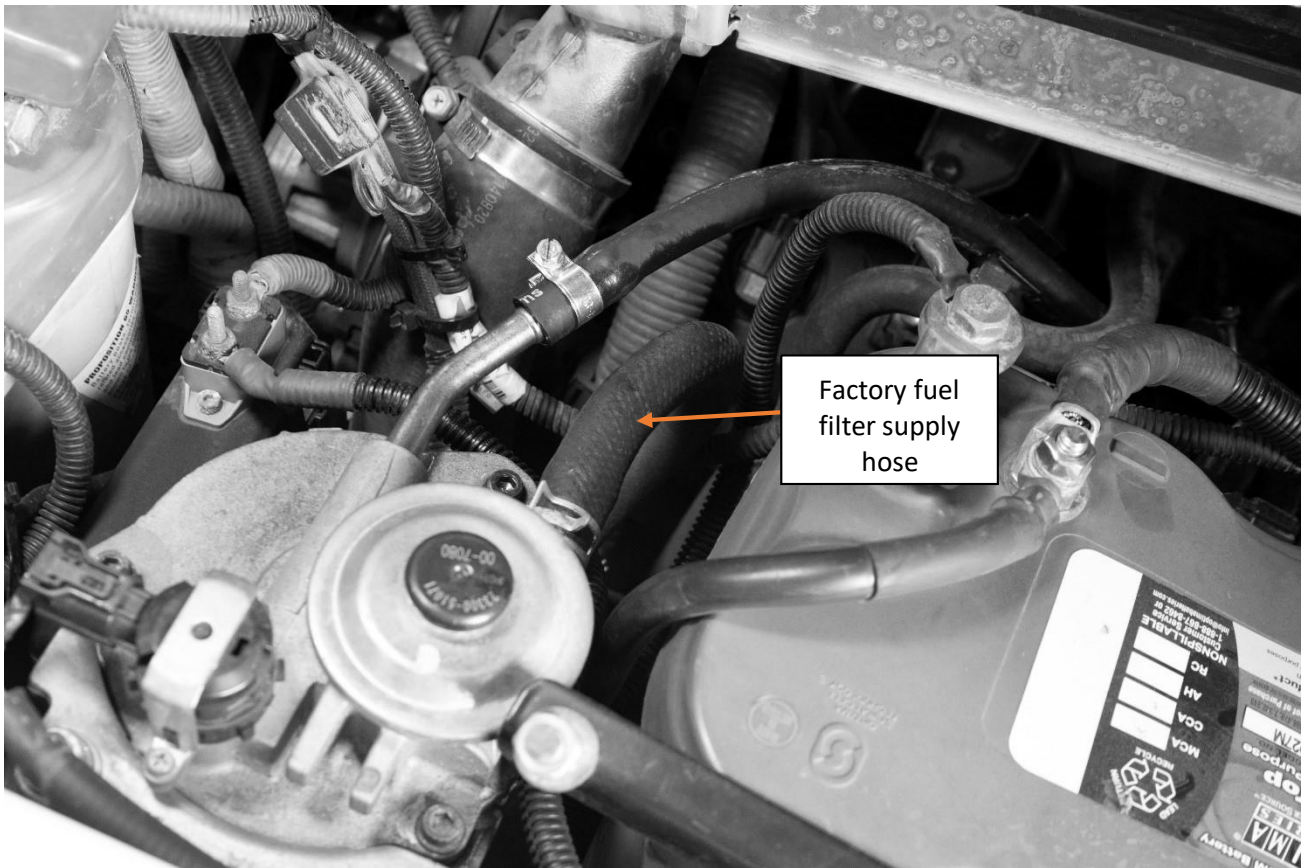

5. Measure from the steel pipe (this pipe comes from the tank) to the inlet port of the FM100 head (the arrows on the head indicate direction of flow) and cut to length a piece of the supplied 12mm hose
6. Lubricate the barbed end of one push-lock fitting and the inside portion of the hose to be fitted with a push-lock fitting with diesel fuel or WD40
7. Insert the barbed end of one push-lock fittings into the pre-lubricated end of the hose. Ensuring that the hose stops firmly against the inside of the bell cover.
8. Install a length of the supplied heat shield over the hose – trim to length if required
9. With the assembled hose, screw the push-lock fitting on to the inlet port of the pre-filter. Routing the hose along the firewall, Connect the other end of the same hose to the steel fuel line coming from the tank and secure using a supplied 12mm fuel hose clamp

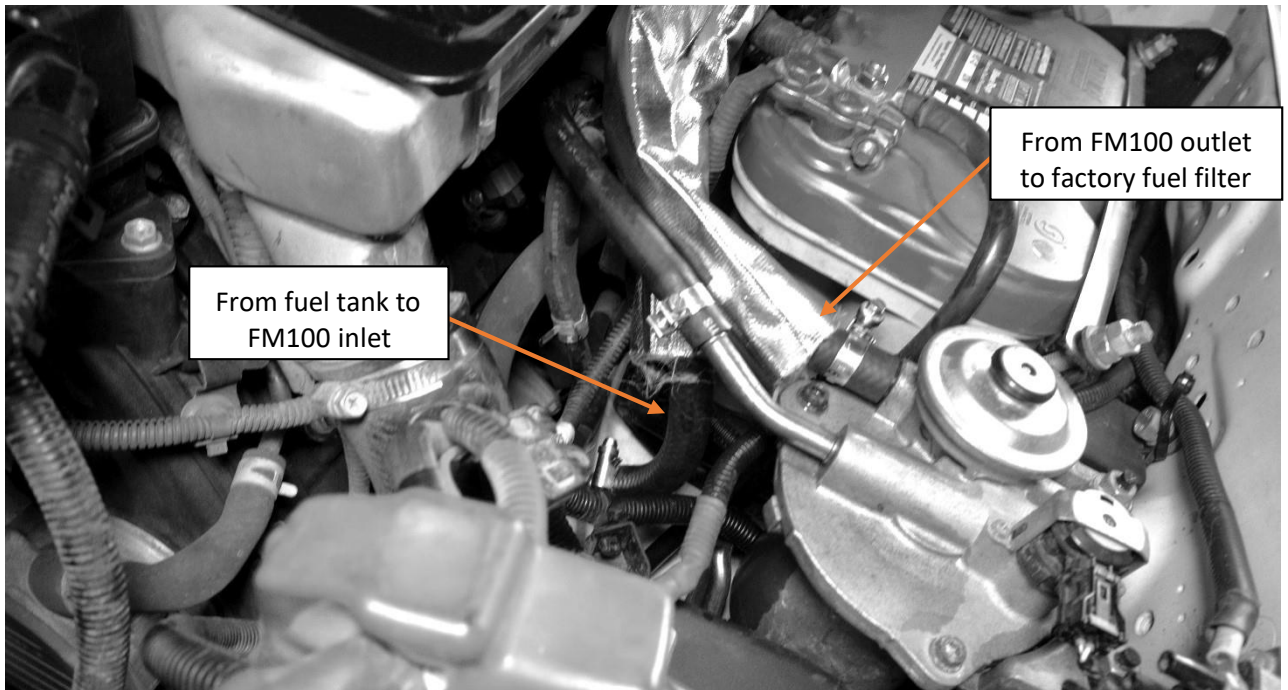

10. Lubricate the barbed end of the remaining push-lock fitting and the inside portion of the remaining hose to be fitted with a push-lock fitting with diesel fuel or WD40
11. Insert the barbed end of the remaining push-lock fittings into the pre-lubricated end of the hose. Ensuring that the hose stops firmly against the inside of the bell cover
12. Install a length of the supplied heat shield over the hose – trim to length if required
13. With the now assembled hose, screw the push-lock fitting on to the outlet port of the pre-filter
14. Routing the hose along the firewall, measuring the hose in place between the outlet port of pre-filter the inlet of the factory fuel filter. Cut the hose to length
15. Connect the 12mm fuel hose to the inlet of the factory fuel filter and secure with a supplied 12mm fuel hose clamp



16. Using the supplied nylon cable ties, secure any loose hose from rubbing on any other components
17. Bleed the fuel system by pumping the hand primer on the factory filter until firm – **note it is easier to prime the system if the FM100 element is filled with clean diesel before using the hand primer.**
18. Start vehicle and run the vehicle, whilst checking all connections for leaks
19. Refer to supplementary instruction for water alarm connection

End of Installation Guide