

## Installation Guide of Direction-Plus Fuel Manager Pre-Filter for Ford Ranger / Everest 2022+

This document is to be used as a guide for the installation of the **Direction-Plus Fuel Manager pre-filter kit to a 2022+ Ford Ranger / Everest 4cyl and 6cyl Diesel**. It is recommended that the installation of the product be carried out by a competent qualified mechanic.

### Important Before Starting

- Ensure you have the correct tools to complete the fitment.
- Read the instructions in full and familiarize yourself with the installation, before commencing any work

### Maintenance / servicing

- It is recommended to drain the FUEL MANAGER element every 5,000 – 10,000km.
- FUEL MANAGER element is to be replaced every 40,000km or as per your vehicles service interval.

### Included in the kit:



<i>Pre-assembled</i>	<i>Hardware Bag</i>	<i>Mounting Kit Bag</i>
1 x Fuel Manager PRE-FILTER	1 x Bracket (PL671-BR)	2 x M10x30 Bolts
2 x M16x1.5 to -6 Adaptors	2 x M6x16 Bolts	2 x M10 Flat Washers
2 x -6 to 3/8" 90° Fittings	2 x M6 Spring Washers	2 x M10 Spring Washers
4 x M16 Alloy Washers	4 x M6 Flat Washers	
2 x M16x1.5 Plugs	2 x M6 Nyloc Nut	
	2 x 15-17mm Hose Clamps	
	1 x 3500mm 3/8" Fuel Hose	
	1 x Male 3/8 QR to 3/8 Adaptor	
	1 x Female 3/8 QR to 3/8 Adaptor	
	1 x 180 Deg Push on Hose Adaptor	
	10 x 200mm Cable Ties	

## Mounting Location



### Tools Needed:

- Spanners
- Sockets
- Screw Drivers
- Pliers
- Snips/Cutter
- Rags
- Small container for priming
- We suggest using a thread sealant like Loctite 567 or equivalent.

## Fuel Manager Pre-Filter Normal Flow Header Connection

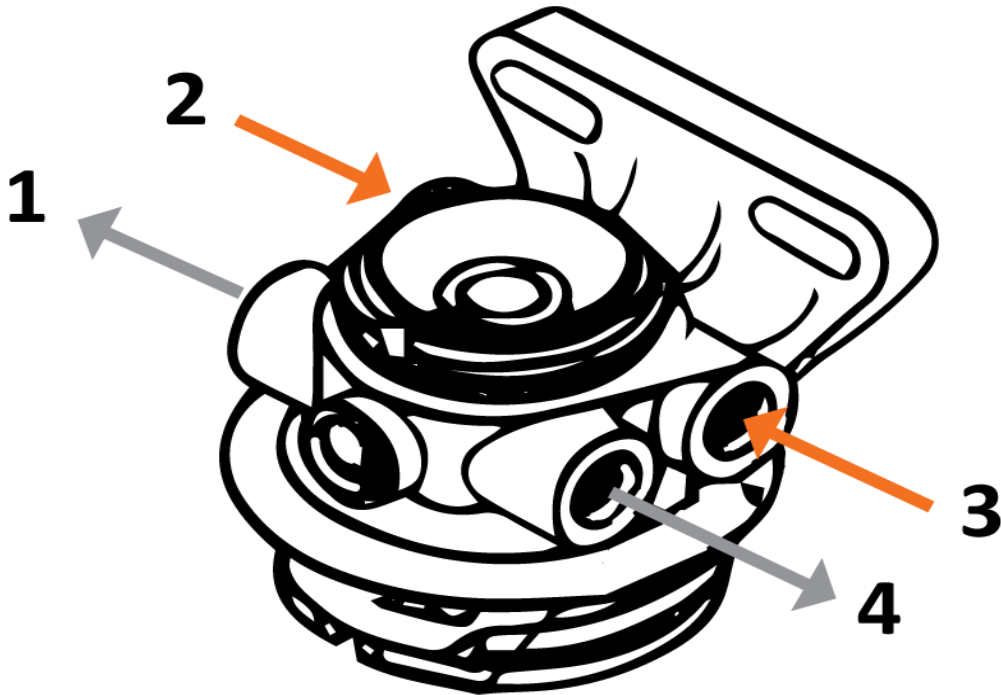

**Ports 2 and 3 = INLET**  
**Ports 1 and 4 = OUTLET**

## Installation Guide

1. Begin by removing the bolt that secures the battery tray to the radiator support panel.

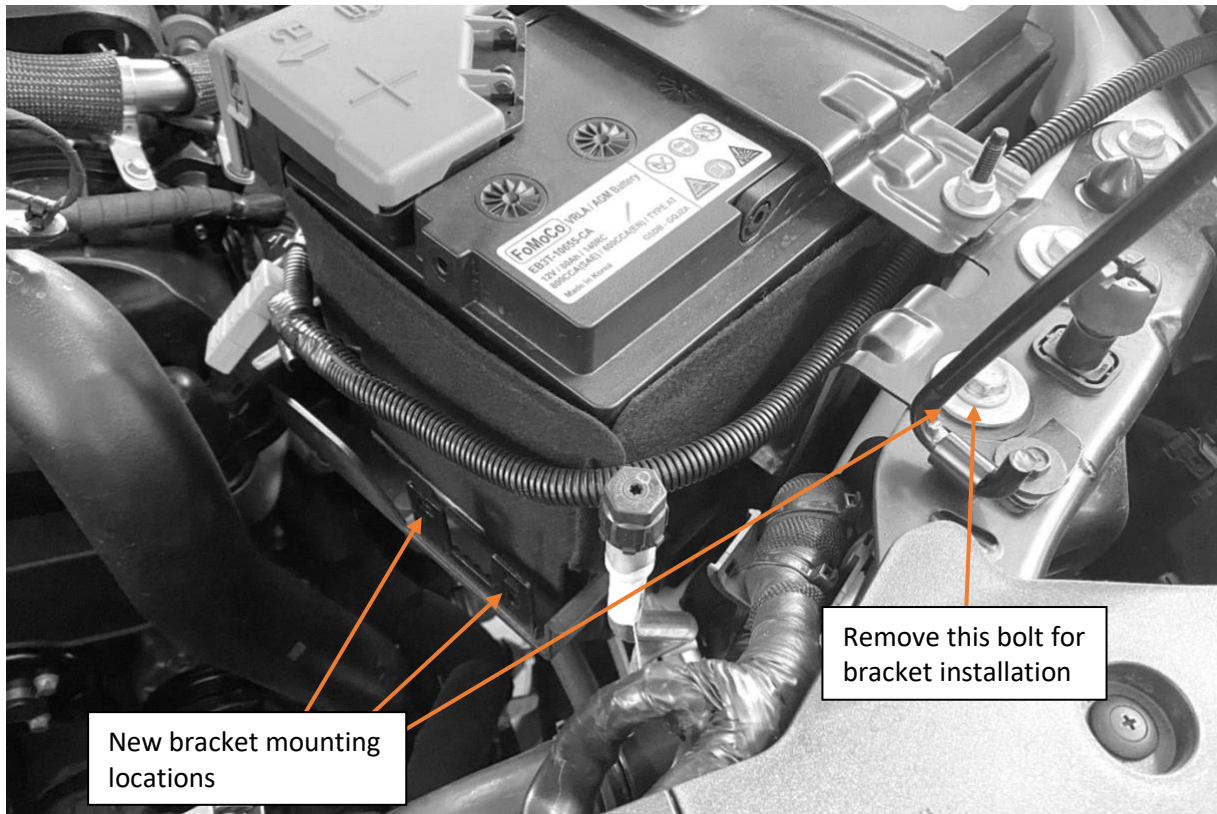

2. Using the M6x12mm bolts, four flat washers and M6 nyloc nuts, secure the bracket in place as per the photo below. Re-install the original Battery tray bolt removed in step 1.

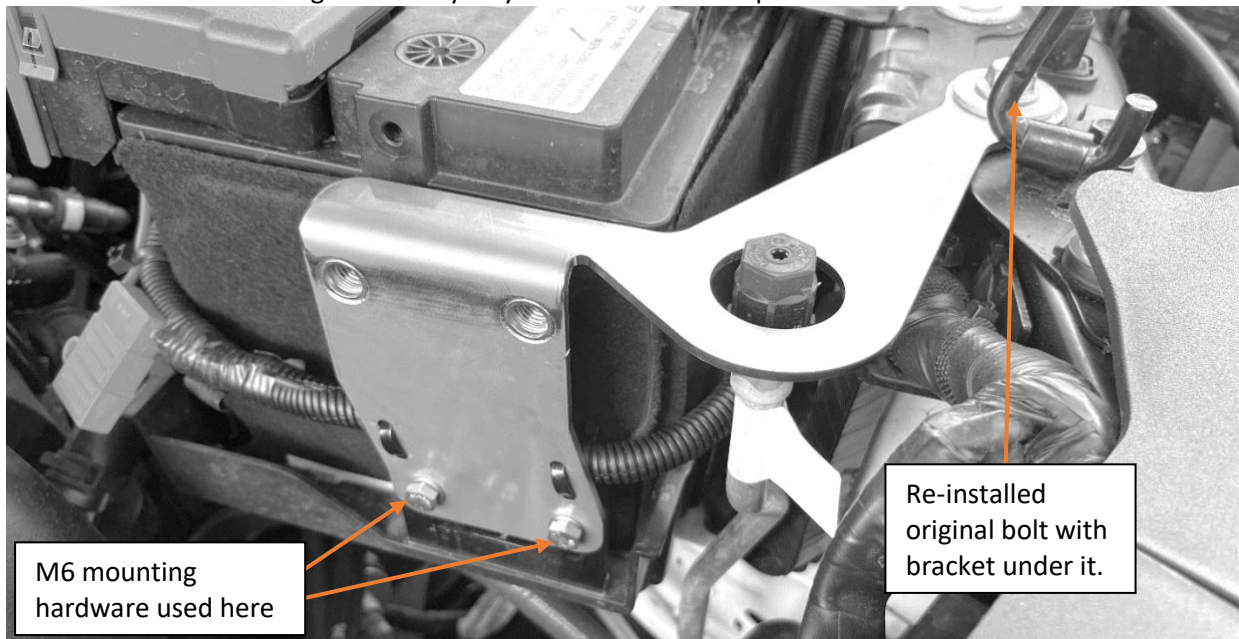

3. Install the threaded adaptors and blanking plugs onto the FUEL MANAGER PRE-FILTER, using the M16 washers between the filter head and the fittings. Make sure to use a sealant like Loctite 567 or equivalent. Keep the exposed -6 thread clean when installing.



*Fuel Manager in place on bracket with M16x1.5 to -6 Adaptors and Plugs installed*

4. Install the FUEL MANAGER PRE-FILTER to the fuel filter bracket using the two M10x30 bolts, 2 x spring washers and 2 x flat washers.

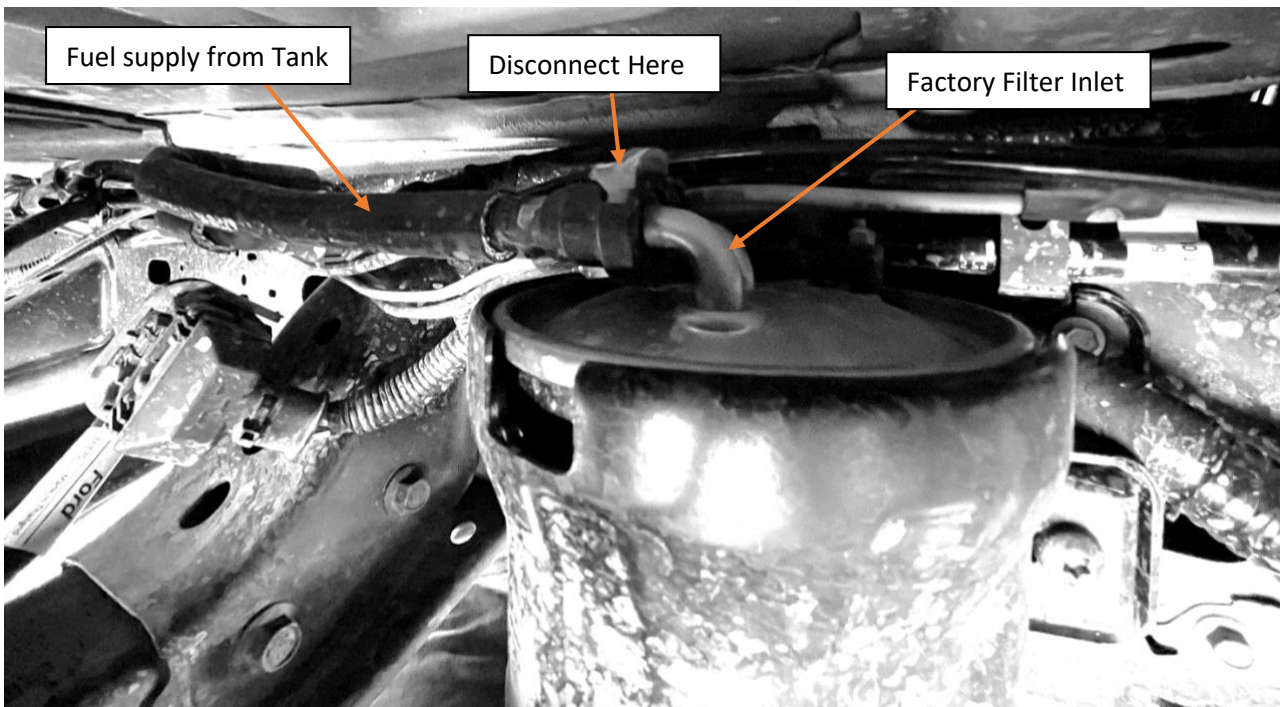

*Factory Fuel Filter hose locations*

5. Install the first -6 90° hose fitting to one end of the hose. Make sure the hose is seated all the way on the push lock fitting. Finally, suggest applying Loctite 567 to the -6 thread on the supply port adaptor in the fuel filter before securing the 90° -6 hose fitting in place.

6. Find the factory fuel hose that supplies the factory fuel filter under the passenger side of the vehicle. Run the new hose to this location measure and cut it to length. Install the 3/8 QR male fitting with a hose tail on it into the end of the hose and secure with one of the new hose clamps.
7. Disconnect the factory 3/8 QR female fitting from the inlet to the factory fuel filter. Install the new 3/8 QR male fitting with the hose secured to it into this connector making sure it seats all the way.
8. Install the second -6 90° hose fitting to one end of the remaining hose. Make sure the hose is seated all the way on the push lock fitting. Finally, suggest applying Loctite 567 to the -6 thread on the return port adaptor in the fuel filter before securing the 90° -6 hose fitting in place.
9. Run the remaining new hose to the top of the stock fuel filter you removed the female 3/8 QR fitting from earlier, measure and cut to length. Install the new female 3/8 QR fitting with a hose tail in the kit to the end of the hose and secure with one of the new hose clamps.
10. Connect the new female 3/8 QR fitting to the male port on the top of the factory fuel filter. Take care to make sure it seats all the way.
11. Open the bleed port on the new pre filter head and prime the system to remove the excess air in the new filter and lines. Once bled close the bleed port in the filter head.

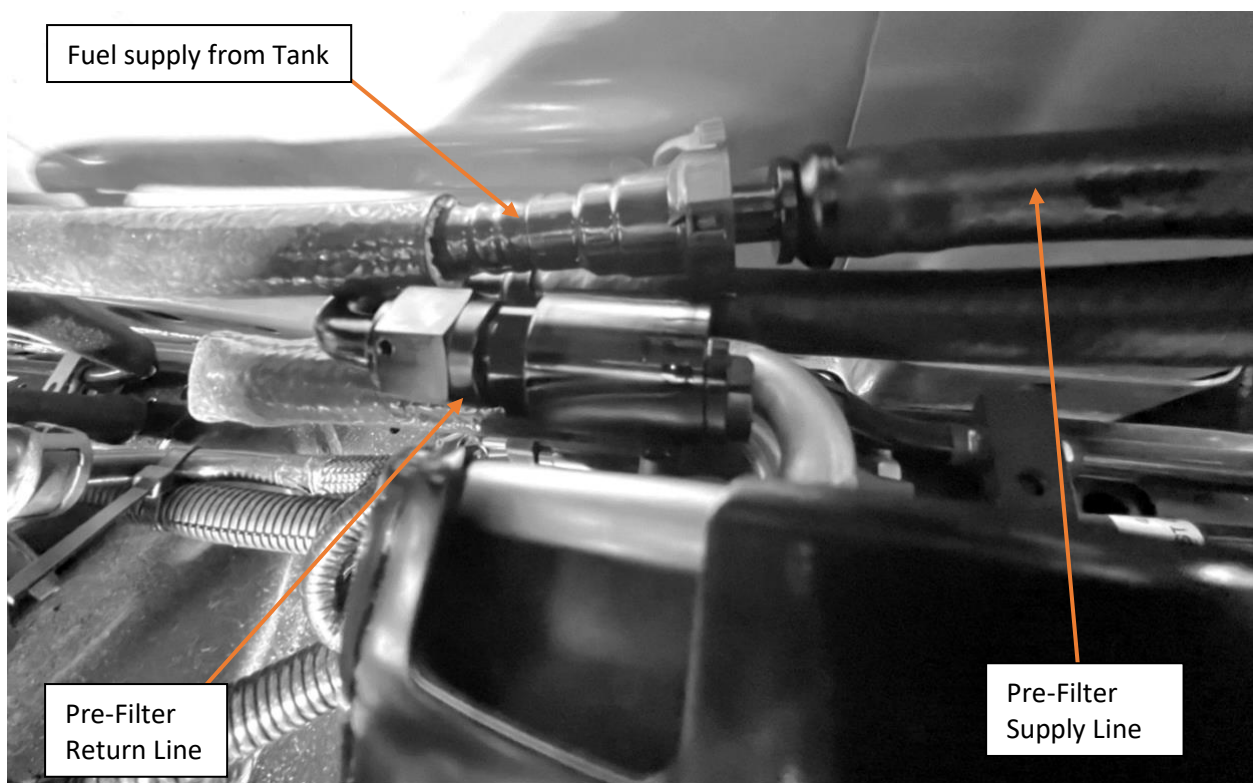

*Ranger 2022+ Pre-filter fuel hose installed*

12. Once complete start the vehicle, carefully and thoroughly check for leaks.
13. Run the vehicle for at least 20 minutes to ensure there are no air pockets in the fuel system.



*Fuel hose routing for pre-filter on Ranger 2022+*

**End of Installation Guide**