



# Toyota Prado 150 1KD-FTV / 1GD-FTV

## Direction-Plus™ Pre-Filter Kit Installation Guide

This document is to be used as a guide for the installation of the Direction-Plus™ Fuel Manager™ FM100 pre-filter Kit to a Toyota Prado 150 1KD-FTV / 1GD-FTV. It is recommended that the installation of the product be carried out by a competent qualified mechanic.

### Important before starting

- Ensure the engine bay is clean and free from contaminates
- The fuel manager filter head has direction arrows indicating the direction of flow
- You have the correct tools to complete the fitment
- Read the instructions in full and familiarize yourself with the installation, before commencing any work

### Kit contents

|   |   |
|---|---|
|   | 1 |
|   | 2 |
| WASHER 6MM X 25MM                         | 1 |
| 1/4" NPT STRAIGHT - 10MM 2 BOLTS 2 NUTS 4 | 1 |
| WASHERS                                   | 1 |
| BOLT - 6X25MM ZINC                        | 1 |
| BRACKET - PRADO 150 FACE LIFT             | 2 |
| DFL10 - FUEL LINE RUBBER (10MM)           | 1 |
| DP733-04 - 1/4 "NPT PLUG                  | 1 |
| ELEMENT ASSEMBLY 30M - 3.6"               | 1 |
| FM ENGINE BAY LABEL                       | 2 |
| FM100 30 MICRON FILTER ASSY               | 1 |
| HOSE CLAMP - 10MM                         | 1 |
| LOCTITE 567 THREAD SEALANT - 6ML          | 2 |
| NUT - NYLOC 6MM                           | 1 |
| PUSH ON STRAIGHT - 10MM                   | 1 |
| WASHER - 6MM                              |   |
| WINDSCREEN LABEL                          |   |

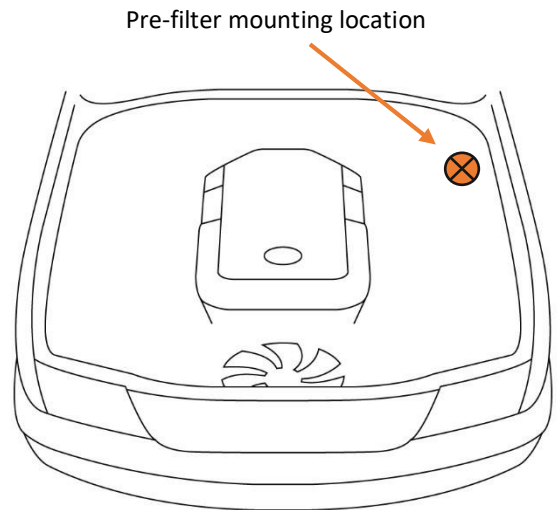

\*Kit contents are subject to change based on component availability and/or refinement

## Fuel Manager Pre-Filter Normal Flow Header Connection

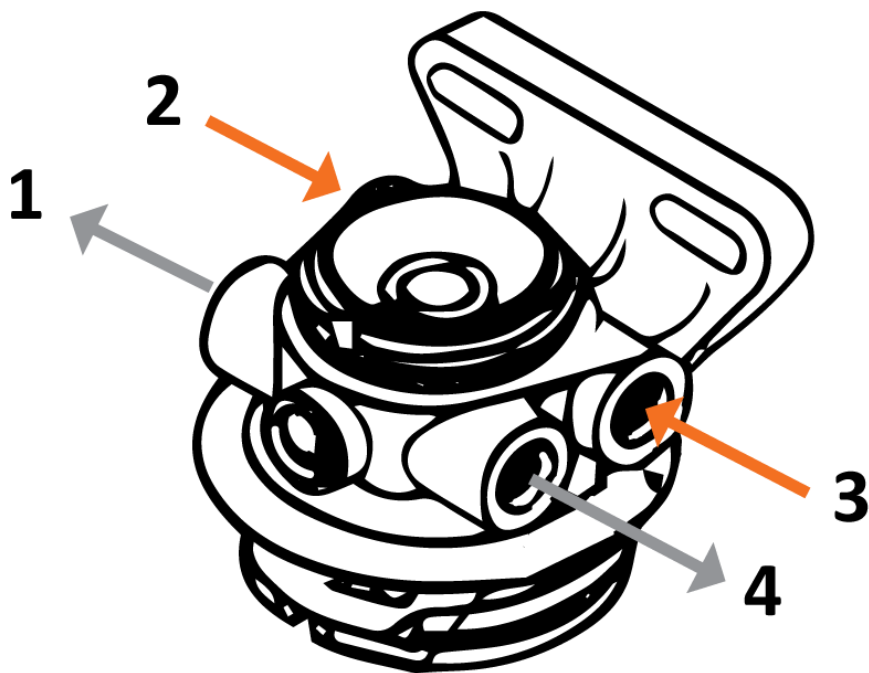

**Ports 2 and 3 = INLET**  
**Ports 1 and 4 = OUTLET**



## **Installation Guide**

1. Disconnect factory fuel filter inlet hose from both ends and remove from the vehicle. Retain this hose in a safe place so the vehicle can be returned to factory in the future
2. Remove the two retaining nuts from the top of the factory filter housing
3. Place the pre-filter mounting bracket into its mounting location, sandwiched between the factory fuel filter and the factory fuel filter mounting bracket
4. With the supplied bolt, nut and washers, secure the base of the bracket ensuring that the large washer is installed on the underside of the guard
5. Install the ¼ NPT adaptors into the filter head ports that are facing towards the front of the vehicle using the supplied LOCTITE thread sealant.
6. Apply a small amount of LOCTITE thread sealant to the two black ¼ NPT plugs and install them into the two remaining ports in the pre-filter head.
7. Using the supplied 10mm bolts, washers and nuts, mount the FM100 Fuel Manager pre-filter assembly filter to the backside of the bracket
8. Measure from the steel pipe on the firewall (this pipe comes from the tank) to the inlet port of the fuel manager head (the arrows on the head indicate direction of flow) and cut to length a piece of the supplied 10mm hose
9. Lubricate the barbed end of one push-lock fitting and the inside portion of the hose to be fitted with a push-lock fitting with diesel fuel or WD40
10. Insert the barbed end of one push-lock fittings into the pre-lubricated end of the hose. Ensuring that the hose stops firmly against the inside of the bell cover.
11. With the assembled hose, screw the push-lock fitting on to the inlet port of the pre-filter. Connect the other end of the same hose to the steel fuel line coming from the tank and secure using a supplied 10mm hose clamp
12. Lubricate the barbed end of the remaining push-lock fitting and the inside portion of the remaining hose to be fitted with a push-lock fitting with diesel fuel or WD40
13. Insert the barbed end of the remaining push-lock fittings into the pre-lubricated end of the hose. Ensuring that the hose stops firmly against the inside of the bell cover.
14. With the now assembled hose, screw the push-lock fitting on to the outlet port of the pre-filter.
15. Measuring the hose in place between the outlet port of pre-filter the inlet of the factory fuel filter, cut the hose to length
16. Connect the 10mm fuel hose to the inlet of the factory fuel filter and secure with a supplied 10mm hose clamp
17. Using the supplied nylon cable ties, secure any loose hose from rubbing on any other components



18. Bleed the fuel system by pumping the hand primer on the factory filter until firm

19. Start vehicle and run the vehicle, whilst checking all connections for leaks

END OF GUIDE